VoyagerUTP™

Keyboard, Monitor & Mouse Extender

Installation and Operation Manual



LIMITED WARRANTY

Dakota Computer Solutions warrants the VoyagerUTP™ to be in good working order for one year from the date of purchase from Dakota Computer Solutions or an authorized dealer. Should this product fail to be in good working order at any time during this one-year warranty period, Dakota Computer Solutions will, at its option, repair or replace the Unit as set forth below. Repair parts and replacement units will be either reconditioned or new. All replaced parts become the property of Dakota Computer Solutions. This limited warranty does not include service to repair damage to the Unit resulting from accident, disaster, abuse, or unauthorized modification of the Unit, including static discharge and power surges.

Limited Warranty service may be obtained by delivering this unit during the one-year warranty period to Dakota Computer Solutions or an authorized repair center providing a proof of purchase date. If this Unit is delivered by mail or courier, you agree to insure the Unit or assume the risk of loss or damage in transit, to prepay shipping charges to the warranty service location, and to use the original shipping container or its equivalent. You must call for a return authorization number first. Under no circumstances will a unit be accepted without a return authorization number. Contact an authorized repair center or Dakota Computer Solutions for further information

ALL EXPRESS AND IMPLIED WARRANTIES FOR THIS PRODUCT INCLUDING THE WARRANTIES OF MERCHANTABILITY AND FITNESS FOR A PARTICULAR PURPOSE, ARE LIMITED IN DURATION TO A PERIOD OF ONE YEAR FROM THE DATE OF PURCHASE, AND NO WARRANTIES, WHETHER EXPRESS OR IMPLIED, WILL APPLY AFTER THIS PERIOD. SOME COUNTRIES DO NOT ALLOW LIMITATIONS ON HOW LONG AN IMPLIED WARRANTY LASTS, SO THE ABOVE LIMITATION MAY NOT APPLY TO YOU.

IF THIS PRODUCT IS NOT IN GOOD WORKING ORDER AS WARRANTED ABOVE, YOUR SOLE REMEDY SHALL BE REPLACEMENT OR REPAIR AS PROVIDED ABOVE. IN NO EVENT WILL DAKOTA COMPUTER SOLUTIONS BE LIABLE TO YOU FOR ANY DAMAGES INCLUDING ANY LOST PROFITS, LOST SAVINGS OR OTHER INCIDENTAL OR CONSEQUENTIAL DAMAGES ARISING OUT OF THE USE OF OR THE INABILITY TO USE SUCH PRODUCT, EVEN IF DAKOTA COMPUTER SOLUTIONS OR AN AUTHORIZED DEALER HAS BEEN ADVISED OF THE POSSIBILITY OF SUCH DAMAGES, OR FOR ANY CLAIM BY ANY OTHER PARTY.



NOTE: This equipment complies with the requirements of European EMC directive 89/336 EEC in respect of EN55022 Class B, EN 50082-1 and EN 60555-2.

This equipment has been found to comply with the limits for a Class A digital device, pursuant to Part 15 of the FCC Rules. These limits are designed to provide reasonable protection against harmful interference when the equipment is operated in a commercial environment. This equipment generates, uses, and can radiate radio frequency energy and, if not installed and used in accordance with the instruction manual, may cause harmful interference to radio communications. Operation of this equipment in a residential area is likely to cause harmful interference in which case the user will be required to correct the interference at his own expense.

© Copyright 2000. All rights reserved.

No part of this manual may be reproduced, stored in a retrieval system, or transcribed in any form or any means, electronic or mechanical, including photocopying and recording, without the prior written permission of Dakota Computer Solutions.

IBM® AT, and PS/2 are trademarks of International Business Machines Corp.
Microsoft®, Microsoft Windows™ and Microsoft Intellimouse™ are registered trademarks of Microsoft Corp.
Multisync is a trademark of NEC Technologies, Inc.
All trademarks acknowledged

Printed in the USA

Revision 2.52

Manual Part No: 8035-00

INTRODUCTION

Thank you for choosing the VoyagerUTP™. Designed for easy operation, your new VoyagerUTP will allow you to position your Keyboard, Monitor and PS/2 Mouse up to 1,000 feet (300 meters) away from your PC.

Features

This product has a number of unique features that allow transparent remote operation of your PC.

- Access your CPU up to 1,000 feet away using a single CAT 5 twisted pair cable.
- Fully Adjustable Video Equalization - Compensates for loss of image quality due to cable length
- Fully buffered signals to ensure consistent remote operation of your PC
- Intelligent keyboard and mouse emulation ensures the PC boots and operates even when a keyboard, monitor and mouse are not connected.
- Advanced Security. Keep your servers locked away in a remote location.
- Can be used in combination with a keyboard, monitor and mouse switch to give remote access to multiple servers.
- Dual Access version allows for an additional keyboard, monitor and PS/2 mouse through the local unit.

Operation

The VoyagerUTP is simple to operate and works with all PC operating systems - no software is required. Just connect the units up as described and you are ready to work. Complete keyboard and PS/2 mouse emulation ensuring that your computer will not lock up due to loss of keyboard and mouse connection. Your PC will boot even if the remote end of the link is not powered or the keyboard and/or mouse are disconnected.

Compatibility

To operate in various environments and with hardware from many manufacturers, this product has a number of specific features. This product has been tested with a variety of hardware. However, it is impossible to guarantee correct operation with every keyboard, monitor, mouse and motherboard currently on the market.

The VoyagerUTP is compatible with the following equipment:

- **System Unit:** PC/AT, PS/2 and 100% compatible clones. - PC equipped with PS/2 mouse port*
- **Keyboard:** PC/AT, Enhanced Keyboard. Some older XT/AT autosensing keyboards may not be compatible
- **Mouse:** PS/2 Mouse, Microsoft Intellimouse and Logitech 3 button.*
- **Monitor:** VGA, Super VGA, XGA & RGB (Sync-on-Green)

* If your PC does not have a PS/2 style mouse port, the VoyagerUTP may be connected to a serial port of your PC. This is done via a mouse protocol converter (2146-00C). Please contact your dealer for further details. **Note:** When using the Mouse converter, a PS/2 mouse *must* be used as the input mouse to connect to the VoyagerUTP.

GETTING STARTED

This manual describes the VoyagerUTP, installation and operation.

Package Contents

Your Voyager package includes the following:

- 1 VoyagerUTP Local Unit
- 1 VoyagerUTP Remote Unit
- 1 Power Transformer*
- 1 AC Mains Cable
- 2 PS/2 Cables
- 1 Coax VGA Cable
- 1 VoyagerUTP User Manual

* Use only the power transformer supplied with this product.

The VoyagerUTP has a PS/2 type keyboard connector. If your system uses the AT type 5-pin DIN connector or keyboard, adaptors will be required these are commonly available through your dealer.

If your PC does not have a PS/2 mouse port, please see the note under the [Compatibility](#) section on page 1 of this manual.

Cable Requirements

Cables to connect the VoyagerUTP Local unit to your PC's system unit are supplied in the package. Your keyboard, monitor and mouse will plug straight in to the VoyagerUTP Remote Unit. The Local Unit to Remote Unit connection cable is not supplied, if you do not have suitable CAT 5 UTP or STP cable fitted at your site, please consult your dealer.

The Local and Remote Units are connected by industry standard structured cabling (Category 5 UTP/STP, 4-pair) terminated with RJ45 connectors.

The cable used should be solid trunk cable. Stranded patch cable will give poor results over longer distances.

The connector wiring *must* be to EIA/TIA 568. Refer to the wiring chart later in the manual.

Note: That failure to wire the twisted pairs correctly will impair the video quality dramatically and / or prevent correct operation.

This VoyagerUTP extender is designed for use up to a maximum cable length of 1,000ft (300 meters). At this length the video quality should still be acceptable even at a screen resolution of 1024x768 (75Hz).

Although a single continuous length of interconnect cable is preferable, operation is possible through multiple Patch Panels. However, the more patch panels the cable is routed through, the greater the chance of video signal degradation.

 **Under no circumstances should your Voyager interconnect ports be connected to a network.**

QUICK SETUP SYSTEM GUIDE

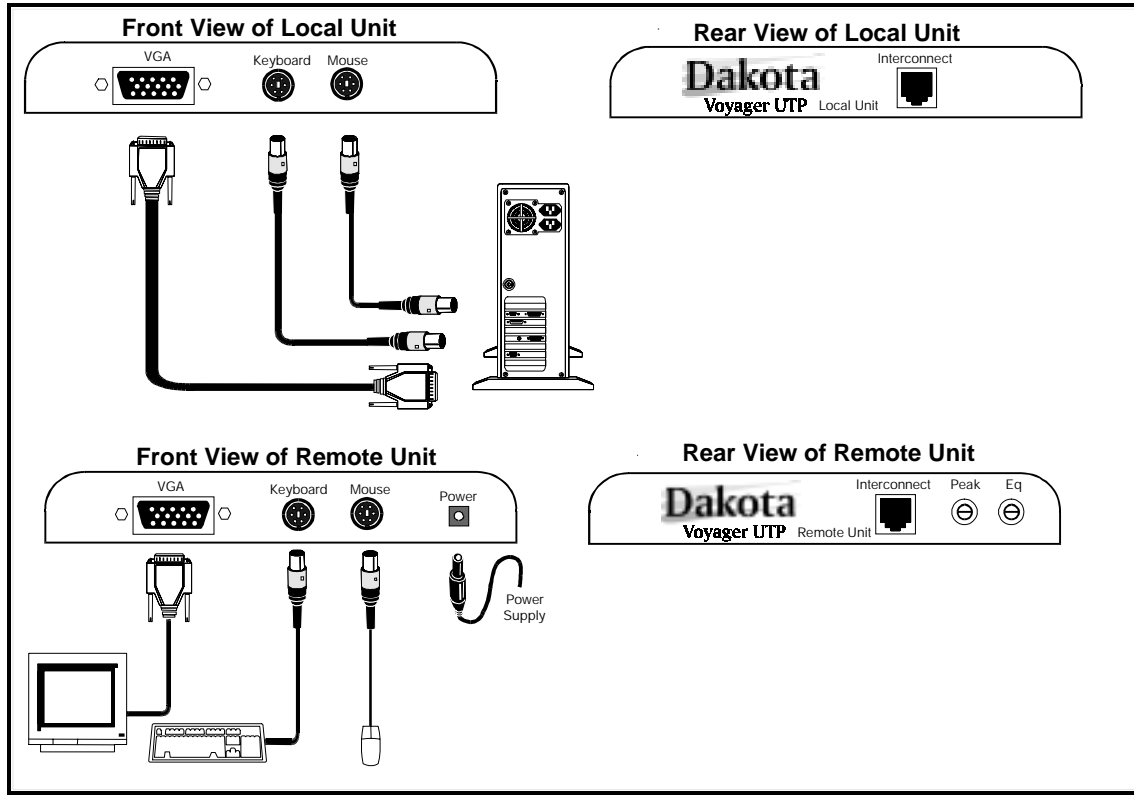

Figure 1. Connecting the VoyagerUTP.

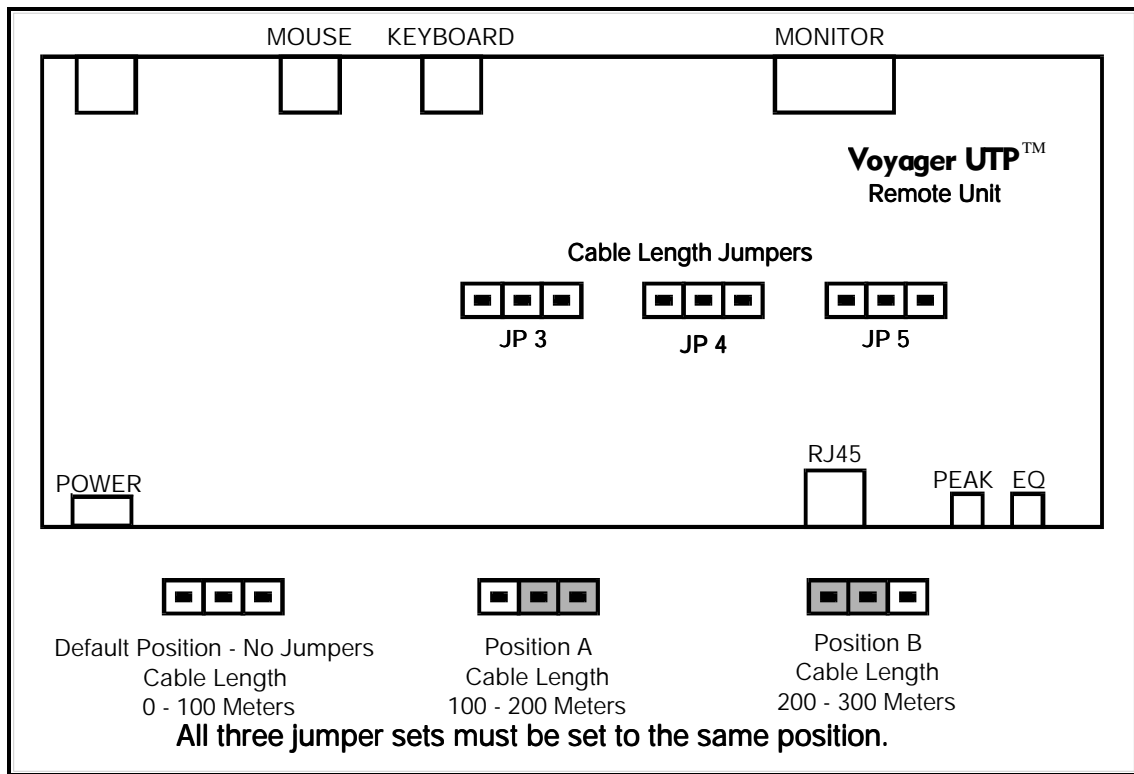

Figure 2. Remote Unit PCB - Cable length jumpers.

Installation Procedure

The VoyagerUTP consists of a Local and a Remote Unit interconnected by a single structured cable that carries all the necessary signals. The Local unit is connected to the PC's keyboard, VGA ports and PS/2 mouse. The keyboard, monitor and mouse are connected directly to the Remote Unit. The Remote Unit is powered by an AC power supply (included) and the PC powers the Local Unit via the keyboard connection. A variable length of Cat5 cable is used to connect the local unit to the remote unit.

 **Under no circumstances should your Voyager ever be connected to a live network cable.**

We recommend that the complete system be tested in one room before permanent installation. If a long interconnect cable is not available, use a patch lead to test basic unit operation with your PC.

Step 1: Setting the Cable Length Jumpers

The Remote Unit contains video equalization circuitry which compensates for loss in image quality experienced when driving over long cables.

To set the correct level of equalization there are three jumpers on the circuit board used to select an adjustment range appropriate to the cable length (these only need to be set once), and two rotary controls on the front panel to precisely alter the compensation level and so 'tune in' the image for the cable length used.

The three cable length jumpers should be set as follows:



Cable Length (Meters)	Remote Unit Jumper Position
0 - 100 (0 - 330 ft)	No Jumpers (Default)
100-200 (330 - 650 ft)	A 
200-300 (650-1000 ft)	B 
(Orientation: RJ45 towards you)	

Figure 3. Cable Length Jumper Setting.

Figure 2 shows where the jumpers are located on the Remote Unit PCB. If you are unsure about opening the case and setting the jumpers, please consult a technician or call for technical support.

All three jumpers *must* be set to the same position.

If you are conducting a test in one room before final installation, set the jumpers as appropriate for the test cable length.

Step 2: Connecting Up

Figure 1 illustrates how the units are interconnected.

1. Switch off your PC and connect the VoyagerUTP, keyboard, monitor and mouse as shown in **Figure 1**.
2. Set the 'Peak' control on the Remote Unit about midway, and set the 'EQ' control fully counter-clockwise (no video compensation).
3. Power up the Remote Unit by connecting the power adapter and switching it on. Use ONLY the power adapter supplied with your Unit.
4. Power on your PC and check that the keyboard operates correctly.
Note: The video image quality may be poor at this point.
5. Boot an operating system (such as Windows) or application you intend to use. Check that the mouse functions (if required). If you have difficulties with your mouse, see the "Troubleshooting" guide later in this manual.

The remote unit (when installed in its final location) may be left permanently powered up.

Step 3: Adjusting the Video Compensation

This step is only required if your cable length exceeds 80ft (25m).

1. Load an application you intend to use that requires a high screen resolution (such as a Windows word processor).
2. If the video is **under-compensated**, you will notice black smearing on the right-hand edge of large horizontal objects such as title bars. The degradation becomes more noticeable as cable length increases.
3. Look at a point on the monitor where the smearing is evident. Now, rotate the 'EQ' control clockwise until the smearing disappears and the edge becomes very bright and too sharp. At this point and beyond the video is **over-compensated**.
4. Rotate the 'EQ' control back slightly until you reach a point where the edge looks normal (no smearing or over sharpness). The compensation is now adjusted correctly for the length of interconnection cable used.
5. The 'PEAK' control is used to adjust the brightness of the overall picture. After adjusting this control to suit, the 'EQ' control may need a very slight readjustment.

Please note that for all practical purposes cable equalization cannot be exact - the remote image will never be as sharp as the original. The VoyagerUTP's equalization system is designed so that it produces very good results on short to medium length cables and an acceptable quality over longer cables (> 480ft/150m).

TIP: If you are at the top end of a cable length range, say 250ft (80m), and you are using high resolution (1024x768 or more) you may achieve better quality video compensation by selecting the next cable length range.

On any cable range you can view how the video would appear without any compensation by simply turning the 'EQ' control counter-clockwise to the stopping point.

Keyboard & Mouse Emulation

The VoyagerUTP uses a microprocessor to emulate the keyboard and mouse. This means that a keyboard and/or mouse do not have to be connected to the Voyager's Remote Unit for your PC to boot. The PC will boot with only the Local Unit of the VoyagerUTP connected.

This feature ensures that your PC will always operate regardless of whether the Remote Unit is actually connected or powered. The remote keyboard and mouse may be plugged in and out at any time.

'Scroll Lock' Reset

The VoyagerUTP redefines the Scroll Lock key as a **device reset**. Whenever you reconnect a keyboard or mouse to the Remote Unit, press 'Scroll Lock' to reinitialize them. You should also press 'Scroll Lock' should the keyboard or mouse ever lock up.

Should you need to use 'Scroll Lock' for a software application, please call technical support.

Mouse Sync (Null Mouse Command)

The Voyager UTP allows recovery of the mouse should it ever go out of sync (mouse pointer jumps over the screen).

Use the following procedure to recover the mouse:

1. Press and release the Scroll Lock key (twice on local console) to reset the keyboard and mouse.
2. Check if the mouse is now operating correctly.

If the mouse is still erratic, issue the following Null mouse command to re-synchronize the mouse.

3. Press and hold down the left and right mouse buttons.
4. Press and release the Scroll Lock key (and then release the mouse buttons).
5. Check if the mouse is now operating correctly. If not, repeat steps 3 and 4 up to three times.

The Null Mouse Command sends a single null byte to the PS/2 mouse port. By issuing this command up to three times the Voyager UTP mouse reports will become re-synchronized with the order expected by the PC. Ordinarily, the mouse should never go out of sync. However, this command provides a recovery mechanism avoiding the need to reload the mouse driver or reboot the machine should this condition occur.

Note: Issuing the Null Mouse Command when the mouse is operating correctly will cause it to go out of sync (unless the mouse driver is auto-correcting).

Local / Remote Console Switching

The VoyagerUTP Dual Access version allows you to connect an additional keyboard, monitor, and mouse to your system through the local unit. The PC may now be operated from either of two locations, though not simultaneously.

Pressing any key on the keyboard activates a user console; the key press is ignored by the operating system. The console is now active. The other console cannot operate while the active console is in use. If the active console's keyboard or mouse are not used for more than 15 seconds, control is taken by the first console to send a keyboard or mouse signal.

Private Mode (Dual Access Version Only)

The Private Mode feature will disable the remote keyboard, monitor and mouse. To enter Private Mode, press Scroll Lock on the local keyboard. The Scroll Lock LED will now light on both local and remote keyboards. Press Scroll Lock again to re-enable the remote console. Scroll Lock will also re-initialize the local keyboard and mouse. The local console is active on power up.

When the remote console is powered up, it may take up to 15 seconds to be initialized. This will result in a blank screen.

Jumper JP1 (normally off) in the Remote Unit can prevent the remote monitor from being blanked when in private mode. Connect this jumper to prevent screen blanking.

UTP / STP Connection Cable Wiring

The Local-Remote interconnection cable is terminated in RJ45 connectors and should be wired according to the EIA/TIA 568 (Scheme B preferred) industry standard.

Orientation: Looking into the RJ45 socket on the VoyagerUTP unit, Pin 1 is on the left and Pin 8 on the right.

Pin	Wire Colour	Wire Pair
1	White/Orange	T2
2	Orange/White	R2
3	White/Green	T3
4	Blue/White	R1
5	White/Blue	T1
6	Green/White	R3
7	White/Brown	T4
8	Brown/White	R4

The VoyagerUTP has been tested with all major makes of CAT 5 cable including BICC-VERO, Mohawk, AT&T.

TROUBLESHOOTING

Keyboard

- **The PC boots fine with no error messages but the remote keyboard does not work at all.**
 - a) Cable is loose, re-seat keyboard cable and press 'Scroll Lock'
 - b) Wrong cable plugged in, keyboard and mouse cables reversed.
 - c) Try a different model of keyboard. If the new keyboard works then original one may be incompatible, (some older auto-sensing units may not work with this product).
- **Wrong or missing characters from those typed.**
 - a) The keyboard may be in the wrong mode. Press 'Scroll Lock' to reset it.
 - b) Power down and reboot the entire system.
- **The PC always comes up with "Keyboard Error "**
 - a) Press F1 or ESC. If the system appears to work fine after pressing F1 (or ESC) adjust your BIOS set-up so that the PC does not test the keyboard.
- **Connecting a keyboard to the unit affects the Video.**
 - a) Change to a newer keyboard. Some older keyboards require a large amount of current.

PS/2 Mouse

- **I have a mouse cursor on the screen, but the mouse does not work**
 - a) Press 'Scroll Lock' on the keyboard to reset the mouse.
 - b) Cable is loose, re-seat mouse cable and press 'Scroll Lock' a number of times
 - c) Wrong cable plugged in, keyboard and mouse cables reversed.
 - d) Try a different model of mouse.
 - e) Power cycle the remote unit.
- **The system does not detect a PS/2 mouse, or the application cannot find the mouse.**
 - a) Wrong cable plugged in, keyboard and mouse cables reversed on Local Unit.
 - b) Cable is loose, re-seat mouse cable between Local Unit and CPU and press 'Scroll Lock' a number of times.
 - c) Ensure that the keyboard input cable to the Local Unit is connected to provide power.
 - d) Reboot PC.
- **The mouse movement is erratic**
 - a) Press 'Scroll Lock' to reset the remote keyboard and mouse.
 - b) Issue the Null Mouse Command.
 - c) Try installing a self-correcting mouse driver such as the Microsoft Intellimouse™ Driver.

Keyboard & Mouse

- **Neither the keyboard or mouse operate, or have locked up**
 - a) Reset Keyboard and mouse by pressing 'Scroll Lock' a number of times.
 - b) Reset PC and the Voyager Remote unit.
 - c) Check power to the remote unit.
 - d) Some PC's have a port re-mapping feature which allows a keyboard or mouse to be plugged into either PS/2 port. Try crossing over the cables between the local unit and PC. (i.e. KB to Mouse & Mouse to KB.)

Video

- **The picture is not sharp & is very smeary**
 - a) Video compensation incorrectly set - See installation section.
- **Each character has separated into overlapping red, green & blue pixels. (Like looking through 3D glasses).**
 - a) Check that the UTP / STP wiring used throughout is EIA 568 standard.
 - b) Check patch panels for poor or incorrect connections
 - c) Check the compensation jumper settings for proper distance.
- **The monitor sometimes loses sync causing it to go blank for a second or two**
 - a) This occurs if your electrical power system is very noisy (particularly ground).
- **Video only required, but no picture appears**
 - a) The Local Unit must be connected to the PC's keyboard port.
 - b) Consult technical support if you cannot do this and require a secondary power supply for the Local Unit.
- **A constant vertical wobble appears down the screen (interference).**
 - a) The interconnection cable could be located too close to a source of very strong electrical interference, re-route cabling if possible
 - b) If interference is from strong signals from a nearby broadcast transmitter a beat pattern will appear. Change the vertical refresh rate of video card slightly, such as from 65Hz to 70Hz.
- **Video Picture is black and white not color**
 - a) Your system requires a monitor ID code to boot into the correct video mode. Please contact technical support on details to correct this.
- **Windows or Windows NT will only boot into a low-resolution graphics mode.**
 - a) The problem could be Monitor ID. See above.
 - b) If your graphics card supports VESA DDC (Display Data Channel) configure the graphics driver by explicitly telling it which make and model of monitor you have rather than using DDC.
 - c) Disable the option "Automatically detect plug and play monitors". This command is found in Control Panel/Display Properties/Settings (tab)/Advanced (button)/Monitor(tab).

GENERAL QUESTIONS

- **Is it possible to use a cable length of more than 1,000ft (300m)?**

The VoyagerUTP has been designed to produce acceptable results with Super VGA resolutions at the maximum cable length. It may be possible to run up to 1,600ft (500m) at the standard VGA resolution (640x480). However, we cannot guarantee that this will work in every instance.

- **Can VoyagerUTP units be chained to allow operation over more than 1,000 feet (300 meters)?**

Two units may be chained to allow operation over longer distances. Using cascaded units, Super VGA operation over 1,600ft (500m) and standard VGA operation over 1,920ft (600m) is possible, though not guaranteed. In general, the first segment of cable length should be around 640ft (200m) with the remainder in the second segment. Careful calibration of the video equalizers is required. If you plan to cascade units, please contact technical support to discuss your application.

- **Which cable is better UTP or STP?**

UTP cable will give the best quality video over long distances because it has less capacitance per unit length. However, STP may be a better choice in electrically noisy environments.

- **When using UTP what is the best way to ensure the system does not suffer from any interference?**

This product is designed to withstand high levels of interference while using Cat 5 cable over long distances. To further reduce the potential for interference consider the following:

- a) Ensure that the computer and remote monitor are both connected to the same power phase.
- b) Ensure that the AC voltage across the power ground (at the local PC & remote monitor) is less than 2V.
- c) Use a clean earth system (if your site has one installed).
- d) Route the interconnection cable away from other cables to avoid electrical interference.
- d) Try STP cable if you think electronic noise could be a problem.

- **Is the Voyager UTP suitable for use between buildings?**

The Voyager UTP does not have line isolation. Therefore, operation between buildings is not recommended.

- **Can multiple Local or Remote Units be used, by swapping the UTP cable over?**

The Voyager UTP has full emulation thereby allowing you to swap cables between units. After swapping the cable, press 'Scroll Lock' to resynchronize the Voyager UTP.

- **Is the Voyager UTP connectable to my network?**

The Voyager UTP uses the same cable as your network, ***but it cannot be directly connected into your network. You may damage your Voyager beyond repair if you attempt to do so.***

SERVICE INFORMATION

Maintenance and repair

The unit does not contain any user-serviceable parts. Any malfunction of the unit should be reported to a factory-authorized repair center for service. Any discrepancies in the operation of the unit according to this manual should be reported to the Technical Support Department of Dakota Computer Solutions.

Technical support

If you cannot determine the nature of a problem, please call Dakota Computer Solutions and ask for Technical Support. If possible, call from a telephone located near the unit; we may be able to solve your problem directly over the telephone. If we cannot solve your problem on the telephone, or determine that the fault is in the unit, we will issue a Return Material Authorization (RMA) number that must appear on the outside of all returned products. The unit should be double-packed in the original container, insured, and shipped to the address given to you by our Technical Support representative.

To speak to a Technical Support representative, call (847) 816-1337 from 9:00am to 5:00pm CST, Monday thru Friday.

Voyager UTP Version Numbers & Firmware Updates

A firmware/version number is located on the rear of the Local and Remote Units:

Version Number Format: **xxSyy**

Where **xx** is the hardware revision & **yy** is the firmware revision

Always quote the full version and firmware number when contacting technical support.

APPENDIX A. GENERAL SPECIFICATIONS

Size	Local Unit: 197x100x35 mm - 7.88x4x1.4 inch Remote Unit: 197x100x35 mm - 7.88x4x1.4 inch
Weight	2.35 lbs - 1.07 kg (both units.)
Input Power	Local Unit: From PC Remote Unit: 9V Regulated, 1000mA
Interconnect Cable	CAT 5 Solid UTP/STP EIA/TIA 568 Wiring RJ45 Connectors

Video Bandwidth (-3dB)	Local Unit: 150MHz Remote Unit: 300MHz Over 330 feet (100m) UTP: 95MHz with equalization
Maximum Resolution	1600x1280 (to 200 feet / 65 meters) 1280 x 1024 (to 396 feet / 120 meters) 1024 x 768 (to 1000 feet / 300 meters)
Video I/O	0.7V P-P
Video Compatibility	VGA, Super VGA and XGA
Video Compensation	3-Stage Continuously Variable
Video Coupling	DC
Sync I/O	Separate/Composite TTL level Sync Polarity preserved.

Keyboard Compatibility	PC/AT and PS/2
Mouse Compatibility	Standard PS/2 two Button, Logitech PS/2 three Button and Microsoft Intellimouse
Console Lockout Time Period	15 seconds (Dual version only)

VoyagerUTP Compatible Products	
Description	Part No.
Dakota Scout KVM Switch - 2, 4 & 8 Ports - PC only	1016-02, -04 -08
Vista Native KVM Switch - 2, 4 & 8 Ports - PC only	1017-02, -04 -08
Vista Native KVM with OSD - 4 & 8 Ports - PC only	1018-04, -08
ServeView Plus KVM Switch - 2, 4, 8, 12 & 16 Ports - PC only/Mac only	1115-xx
ServeView Enhanced KVM Switch - 2, 4, 8, 12 & 16 Ports - Multiplatform	1116-xx
Ultra View Plus KVM Switch - 2, 4, 8, 12 & 16 Ports - PC only/Mac only	1117-xx
Ultra View Enhanced KVM Switch - 2, 4, 8, 12 & 16 Ports - Multiplatform	1118-xx
The VoyagerUTP is also compatible with many other devices that use industry standard keyboard, monitor and mouse signals.	
For information regarding these products, contact your Dakota Representative (847) 816-1337.	