

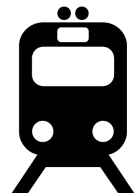

**Galaxy<sup>TM</sup>**

Cat 5 Video Distribution System

Installation and Operation Manual rev 1.1

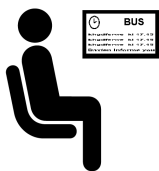

## LIMITED WARRANTY

Daxten warrants the Galaxy™ to be in good working order for one year from the date of purchase from Daxten or an authorised dealer. Should this product fail to be in good working order at any time during this one year warranty period, Daxten will, at its option, repair or replace the Unit as set forth below. Repair parts and replacement units will be either reconditioned or new. All replaced parts become the property of Daxten. This limited warranty does not include service to repair damage to the Unit resulting from accident, disaster, abuse, or unauthorised modification of the Unit, including static discharge and power surges.

Limited Warranty service may be obtained by delivering this unit during the one year warranty period to Daxten or an authorised repair centre providing a proof of purchase date. If this Unit is delivered by mail, you agree to insure the Unit or assume the risk of loss or damage in transit, to prepay shipping charges to the warranty service location, and to use the original shipping container or its equivalent. You must call for a return authorisation number first. Under no circumstances will a unit be accepted without a return authorisation number. Contact an authorised repair centre or Daxten for further information

ALL EXPRESS AND IMPLIED WARRANTIES FOR THIS PRODUCT INCLUDING THE WARRANTIES OF MERCHANTABILITY AND FITNESS FOR A PARTICULAR PURPOSE, ARE LIMITED IN DURATION TO A PERIOD OF ONE YEAR FROM THE DATE OF PURCHASE, AND NO WARRANTIES, WHETHER EXPRESS OR IMPLIED, WILL APPLY AFTER THIS PERIOD. SOME COUNTRIES DO NOT ALLOW LIMITATIONS ON HOW LONG AN IMPLIED WARRANTY LASTS, SO THE ABOVE LIMITATION MAY NOT APPLY TO YOU.

IF THIS PRODUCT IS NOT IN GOOD WORKING ORDER AS WARRANTED ABOVE, YOUR SOLE REMEDY SHALL BE REPLACEMENT OR REPAIR AS PROVIDED ABOVE. IN NO EVENT WILL DAXTEN BE LIABLE TO YOU FOR ANY DAMAGES INCLUDING ANY LOST PROFITS, LOST SAVINGS OR OTHER INCIDENTAL OR CONSEQUENTIAL DAMAGES ARISING OUT OF THE USE OF OR THE INABILITY TO USE SUCH PRODUCT, EVEN IF DAXTEN OR AN AUTHORISED DEALER HAS BEEN ADVISED OF THE POSSIBILITY OF SUCH DAMAGES, OR FOR ANY CLAIM BY ANY OTHER PARTY.

NOTE: This equipment complies with the requirements of European EMC directive 89/336 EEC in respect of EN55022 Class B, EN 50082-1 and EN 60555-2.

This equipment has been found to comply with the limits for a Class A digital device, pursuant to Part 15 of the FCC Rules. These limits are designed to provide reasonable protection against harmful interference when the equipment is operated in a commercial environment. This equipment generates, uses, and can radiate radio frequency energy and, if not installed and used in accordance with the instruction manual, may cause harmful interference to radio communications. Operation of this equipment in a residential area is likely to cause harmful interference in which case the user will be required to correct the interference at his own expense.

© Copyright 2003. All rights reserved.

No part of this manual may be reproduced, stored in a retrieval system, or transcribed in any form or any means, electronic or mechanical, including photocopying and recording, without the prior written permission of Daxten.

# INTRODUCTION

Thank you for choosing the Galaxy™ system, designed for Distributing and daisy chain high-resolution video signals over long distances via CAT 5 cables. By choosing Galaxy, you have assured that your installation is equipped for the ever-increasing demands made in a modern computer-based information environment.

The Galaxy system allows the info-computer to transmit this monitor image to a number of receiver monitors in large environments such as subway stations, bus terminals, airports, restaurants, malls, banks etc.

The Galaxy Tx1 is a base unit with one VGA output and one UTP output.  
The Galaxy Tx4 is a base unit with one VGA output and four UTP outputs.  
The Tx1 and Tx4 can be fitted with different option cards:

- UTP-in Card for up to 125m distance
- UTP-in Card for up to 300m distance
- A skew compensator board
- Sound board on request and requirements

## Features

---

- Up to 300 meters in one line without repeater
- Up to 1000 meters with 10 Galaxy Repeaters in 800 x 600 @ 75 HZ
- Compatible with the Galaxy Rx60 Receiver for building in and the external Rx60, Rx125 or Rx300 version
- Sound or remote operation of monitors ON/OFF on request

## Operation

---

The Galaxy is simple to operate, but need planning before installation, to obtain the best picture quality.

## Compatibility

---

This product has been tested with a wide variety of hardware. However, it is impossible to guarantee correct operation with every monitor currently on the market.

The Galaxy is compatible with the following equipment:

- **Monitor:** VGA, SVGA, XGA, SXGA, UXGA
- **Computers:** all computers using a HD-15 VGA output and standard VGA signals RGB and two sync signals H/V

## GETTING STARTED

This manual describes the Galaxy installation and operation of the Galaxy system.  
All versions of the models are listed here

### Package Content

---

The <b>Galaxy Tx1</b> starter package includes:	(1024-01TK)
1 Galaxy Tx1	(1024-01T)
1 Power Transformer and mains lead*	(9014-00F-AW)
1 VGA Cable	(2051-02T)
1 User manual	

**OR**

The <b>Galaxy Tx4</b> starter package includes:	(1024-04TK)
1 Galaxy Tx4	(1024-04T)
1 Power Transformer and mains lead*	(9014-00F-AW)
1 VGA Cable	(2051-02T)
1 User Manual	

**OR**

The <b>Galaxy Repeater Station Tx1 125M</b> includes:	(1024-01TEHK)
1 Galaxy Tx1	(1024-01T)
1 Expansion Card	(1024-00TUH)
1 Power Transformer and mains lead*	(9014-00F-AW)
1 User Manual	

**OR**

The <b>Galaxy Repeater Station Tx4 125M</b> includes:	(1024-04TEHK)
1 Galaxy Tx4	(1024-04T)
1 Expansion Card	(1024-00TUH)
1 Power Transformer and mains lead*	(9014-00F-AW)
1 User Manual	

- power supply type depends on market .

## Package Content

---

The <b>Galaxy Repeater Station Tx1 300M</b> includes:	(1024-01TEK)
1 Galaxy Tx1	(1024-01T)
1 Expansion Card	(1024-00TU)
1 Power Transformer and mains lead*	(9014-00F-AW)
1 This User Manual	

**OR**

The <b>Galaxy Repeater Station Tx4 300M</b> includes:	(1024-04TEK)
1 Galaxy Tx4	(1024-04T)
1 Expansion Card	(1024-00TU)
1 Power Transformer and mains lead*	(9014-00F-AW)
1 User Manual	

**OR**

The <b>Galaxy Rx60</b> receiver includes:	(1024-01RMK)
1 Galaxy Rx60	(1024-01RM)
1 Power Transformer and mains lead*	(9014-00F-AW)
1 User Manual	

**OR**

The <b>Galaxy Rx60-PCB</b> includes the following:	(PCB-GALRX-60)
1 Galaxy Rx60	(PCB-GALRX-60)

**OR**

The <b>Galaxy Rx125</b> receiver includes:	(1024-01RHK)
1 Galaxy Rx125	(1024-01RH)
1 Power Transformer and mains lead*	(9014-00F-AW)
1 User Manual	

**OR**

The <b>Galaxy Rx300</b> receiver includes:	(1024-01RK)
1 Galaxy Rx125	(1024-01R)
1 Power Transformer and mains lead*	(9014-00F-AW)
1 User Manual	

## Accessories

---

With the packages the units can be set up. It is however necessary to get additional modules and cables to connect the units:

<b>Part</b>	<b>Part number</b>
Galaxy Tx1	1024-01T
Galaxy Tx4	1024-04T
Galaxy Rx60	1024-01RM
Galaxy Rx125	1024-01RH
Galaxy Rx300	1024-01R
Galaxy Repeater Tx1 125m	1024-01TEH
Galaxy Repeater Tx1 300m	1024-01TE
Galaxy Repeater Tx4 125m	1024-04TEH
Galaxy Repeater Tx4 300m	1024-04TE
Expansion Card 125m for daisychain	1024-00TUH
Expansion Card 300m for daisychain	1024-00TU
External 30ns skew compensation unit KIT	1024-00S30-EXT-K
Remote PCB for building in LCD monitors max 60 meter from Tx station	PCB-GALRX-60

## CONNECTORS ON GALAXY

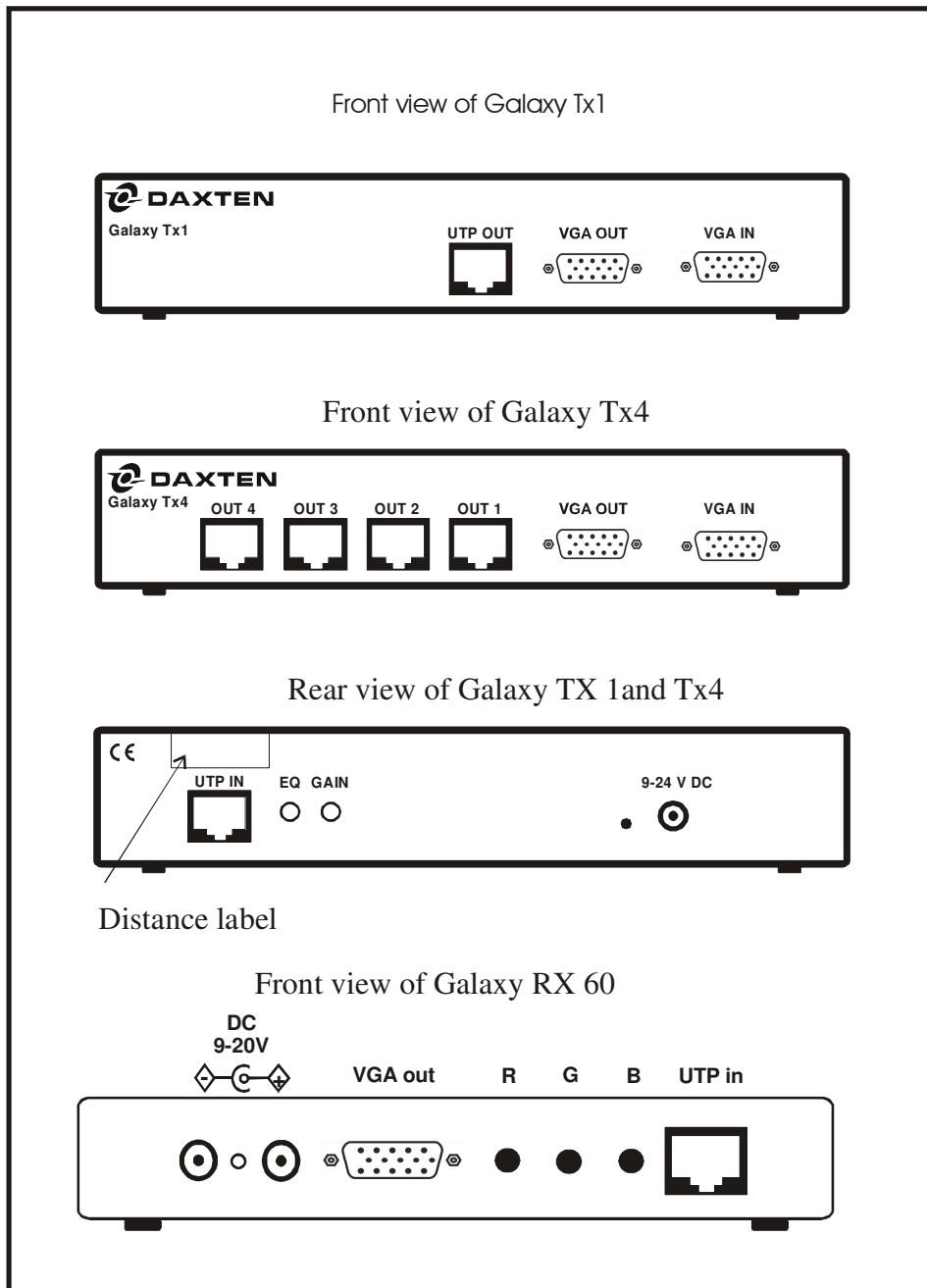

**Galaxy Rx60 DC jack connectors**—There are two DC jack connectors on the Rx60, both of which can accept power supplies giving between 9-20vdc. The second jack connector is available for use in contexts where a TFT screen, for example, is powered by a 19vdc mains adapter. Since the Rx60 only uses 200ma, the TFT mains adapter will normally be able to power the Rx60 as well. This is done by plugging the DC jack from the TFT mains adapter (possibly with the help of a DC jack adapter) into one of the Rx60 DC jack connectors. A jack-jack cable, which must be obtained from a stockist or constructed from components, can then be used to take the 19vdc current from the Rx60 to the TFT screen. This obviates the necessity of a second mains adapter for the Rx60.

# Applications

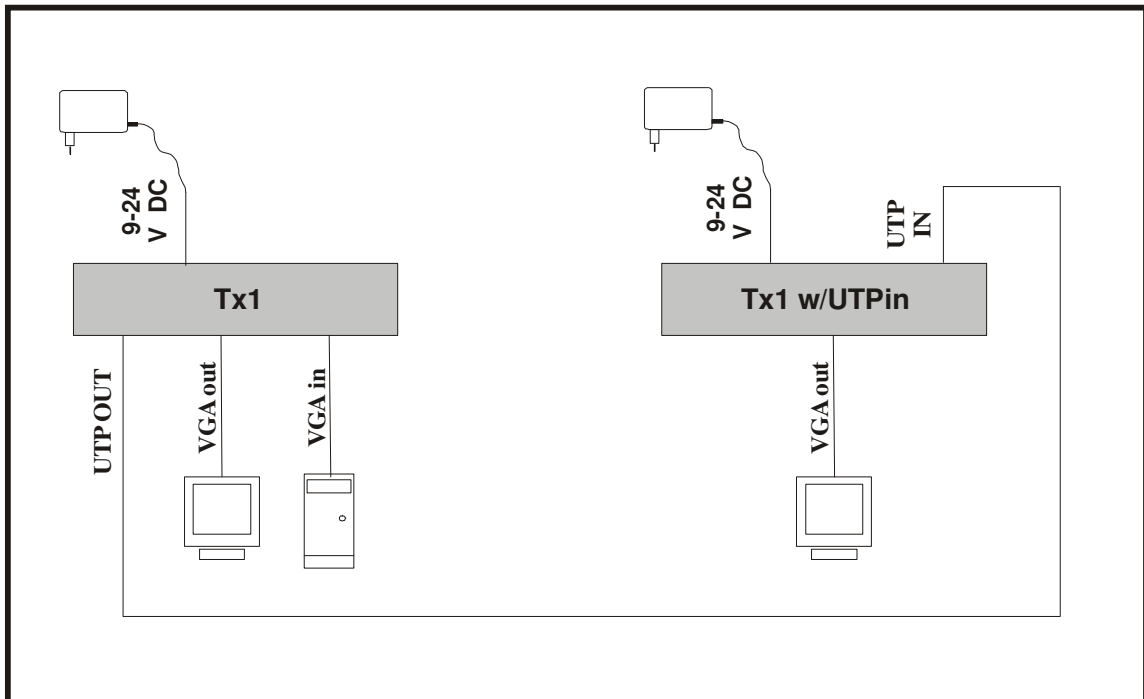
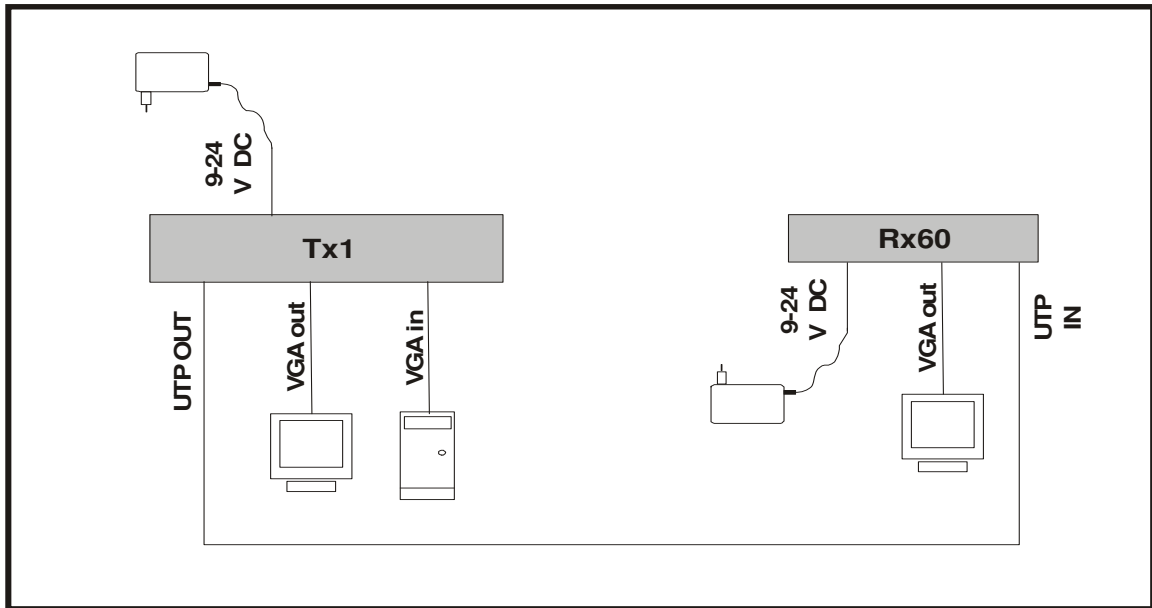
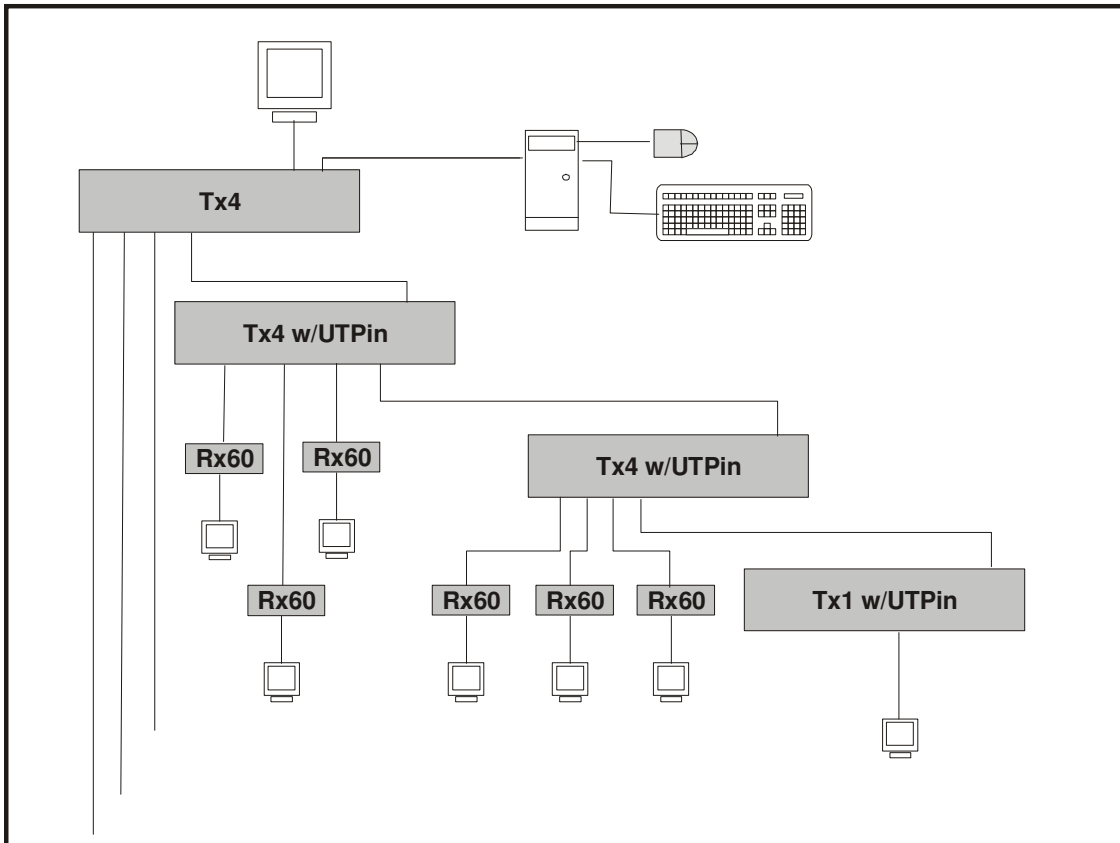
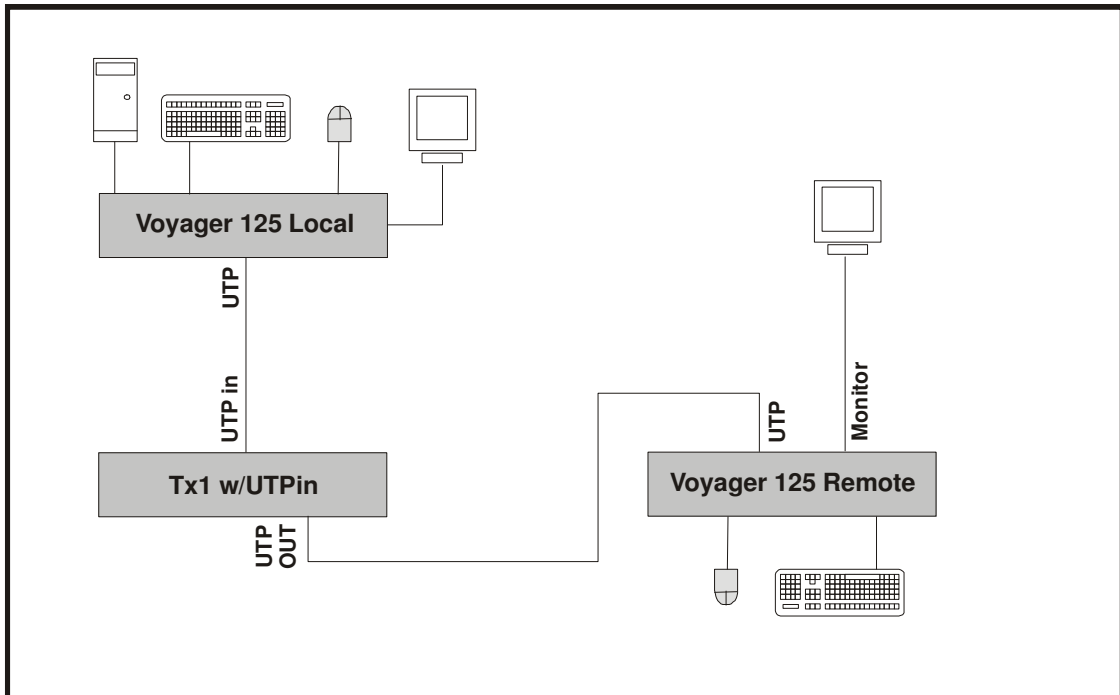

Figure 2: Galaxy Tx1 connected to one Galaxy TX1 with UTP In module



Large-scale system



Galaxy Tx1 with UTP in module used as repeater for high resolution 1200 X 1600 over long distance in a Voyager 125 system

## BEFORE INSTALLATION

### Galaxy Transmitter and Galaxy receivers.

When planning large installations please chose the right boxes and configuration. When working with Daisy chains please make a drawing with cable lengths of your system and give the boxes a numbers so it is possible to locate the boxes on the drawing. Write down the configuration for the box if it contains a delayline so you can put in a spare box with the right settings.

## PROCEDURE FOR INSTALLATION

Begin installation from the info-computer.

Connect a Galaxy Tx1 or Tx4 (without UTP-in module) to the Info-PC.

Put on a still test image on the info-computer.

- A) Connect a Rx60 receiver to the first Galaxy. Connect a monitor to the Rx60; adjust the R G B for the best picture.
- B) OR Connect a Tx1/4 Repeater Station or a Rx125/300; adjust the EQ and Gain for the best picture.

The Galaxy products are made in many versions for special requirements: With and without UTP in modules, with and without delay lines.

The UTP in modules differ in equalizing: the 125M-module work with UTP lines up to 125M. For longer distances use the 300M Version with UTP-in for distances between 125 and 300 m

The 125M version has no inside distance switches.

The 300 version has inside switches for distance adjustment.

### Galaxy Repeater station TX1/TX4 300M and Rx300

Please Notice! The distance of the cat5 cable is set by micro switches inside the Galaxy Repeater 300M/Rx300.

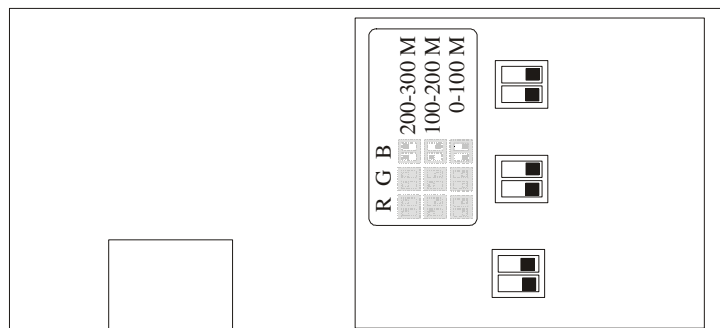
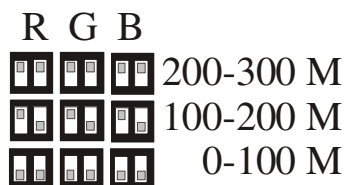

As default the distance is set to maximum 300 M. Changes in distance settings are made inside the Tx Repeater/Rx300.

If the picture has visible vertical shadows it can be improved by adding internal or external delay line.

---

To get the highest picture quality connect a monitor direct to the Tx units to calibrate the EQ and Gain before moving on to the next repeater or receiver box.

After installation adjustments should only be carried out on the monitor settings and Rx60/125/300 ends otherwise the pictures on the other boxes will change.

## TROUBLE SHOOTING

### Video

---

No picture on the Tx1.

- 1) Is the Green LED lit on the unit? No power, no transmission
- 2) Bad picture quality with very long transmission lines—Daxten can, on special order deliver Cat 5E cable optimized for VGA transmission. Adding a delay line (skew delay compensator) will also help.
- 3) Is this receiver fitted with an UTP-in card ? Add one.
- 4) Is the transmitter first unit working? Check local out.
- 5) Check the cables.
- 6) No picture will be showed if you use the VGA input on a Tx fitted with an UTP-in Module.
- 7) Check the UTP cabling if you have problems with the colours.
- 8) If the picture shakes and contains noise you have to isolate the problem by removing the UTP cables to some of the UTP units in order to find the line and box with the problems. Check the ground. Call an electric technician with grounding skills and test equipment for proper grounding.
- 9) The UTP Cables are made the same way as used for networking
- 10) None of the cables for the Information system can be used to carry other data or be connected to any networking equipment.
- 11) Noisy picture if ground problems occur over long distance. These problems are solved by experiments with grounding the housings or adding ground loop isolators. If the voltage potential is large enough, your equipment won't be able to handle the excess voltage and one of your ports will be damaged. You can't test for ground loops. You don't know you have one until picture fails. A ground loop is a current across a conductor, created by a difference in potential between two grounded points, as in two buildings connected by a run of data lines. When two devices are connected and their potentials are different, voltage flows from high to low by travelling through the UTP cable.

## SERVICE INFORMATION

How long distance is it possible to make one line?

The Tx1 and Tx4 has been tested with 900 meters without delay lines at 800x600. To go long distance you need a delay-line compensator to restore the signal.

## ADDING A DELAYLINE

In information systems it is common to work in low resolution. Users are in distance of the display and need larger types. Daylight makes it difficult to work with monitors and displays outdoor. Using smaller displays needs larger types. Try reading your information in two meters is it readable?

If you are running long distance and high resolution pictures with small text you might see that Black don't turn into White. The texts on the monitor have small shadows Put on a test image on the central computer. The best test picture is made of red green and blue lines above each other. If the 3 colour lines do not match on the monitors you need delay-line compensating equipment.

The improvement can be made using an internal or external skew compensator. The Tx1 and Tx4 repeaters can use an internal compensator type Galaxy-TXSK.

## Maintenance and repair

---

The units do not contain any user-serviceable parts inside. Any malfunction of the unit should be reported to a factory-authorized repair centre for service. Any discrepancies in the operation of the unit according to this manual should be reported to the Technical Support Department of Daxten.

## Technical support

---

If you cannot determine the nature of a problem, please call Daxten and ask for Technical Support.

If possible call from a phone located near the unit - we may be able to solve your problem directly over the phone. If we cannot solve your problem, and the fault is supposed to be in the unit, we will issue a Return Material Authorisation (RMA) number that must appear on the outside of all returned products. The unit should be double-packed in the original container, insured, and shipped to the address given to you by our Technical Support representative.

## APPENDIX A. GENERAL SPECIFICATIONS

<b>Galaxy Tx1</b>	
Size	215 x 105 x 44 mm (8.46 x 4.13 x 1.73 in.)
Weight	0.80Kg (1.77lbs)
Power Consumption	Max. 700mA with UTP-in module
Recommended Input Power	Regulated DC 12V/1,3A or 9V/2A

<b>Galaxy Tx4</b>	
Size	215 x 105 x 44 mm (8.46 x 4.13 x 1.73 in.)
Weight	0.80Kg (1.77lbs)
Power Consumption	Max. 700 mA with UTP-in module
Recommended Input Power	Regulated DC 12V/1,3A or 9V/2A

<b>Galaxy Rx60</b>	
Size	160 x 65 x 28 mm (6.30 x 2.56 x 1.10 in.)
Weight	0.35 Kg (0.77lbs)
Power Consumption	Max. 120 mA
Recommended Input Power	Regulated DC 12V/1,3A or 9V/2A

Please note that these specifications are subject to change without prior notice.







# DAXTEN

[www.daxten.com](http://www.daxten.com)

---

## IRELAND

Daxten Ltd  
Unit 5 Distribution Centre  
Shannon Free Zone  
County Clare  
Ireland

[info.ie@daxten.com](mailto:info.ie@daxten.com)

Tel: +353 (0)61 23 4000  
Fax: +353 (0)61 23 4099

•

## ENGLAND

Daxten Ltd  
4 Harp Business Centre  
Apsley Way  
London NW2 7LW  
United Kingdom

[info.uk@daxten.com](mailto:info.uk@daxten.com)

Tel: +44 (0)20 8438 3800  
Fax: +44 (0)20 8438 3899

•

## UNITED STATES

Daxten LLC  
1579 Lexington Road  
Green Oaks, IL 60048  
USA

[info.us@daxten.com](mailto:info.us@daxten.com)

Tel: +1 (847) 816 1337  
Fax: +1 (847) 816 4558

•

## SPAIN

Dakota Computer Solutions S.L.  
C/Francisco de Vitoria 19  
Entrepilanta  
50008 Zaragoza  
Spain

[info.es@daxten.com](mailto:info.es@daxten.com)

Tel: +34 9 76 210 256  
Fax: +34 9 76 219 943

•

## GERMANY

Daxten GmbH  
Salzufer 16, Geb. B  
10587 Berlin  
Germany

[info.de@daxten.com](mailto:info.de@daxten.com)

Tel: +49 (0)30 8595 37-0  
Fax: +49 (0)30 8595 37-99

•

## DENMARK

Daxten  
Finlandsgade 33  
8200 Aarhus N  
Denmark

[info.dk@daxten.com](mailto:info.dk@daxten.com)

Tel: +45 7022 5411  
Fax:

•

## FRANCE

Daxten  
B.P. 04  
77, Route de Cheptainville  
F-91630 Marolles-en-Hurepoix  
France

[info.fr@daxten.com](mailto:info.fr@daxten.com)

Tel: +33 (0)1 64 56 09 33  
Fax: +33 (0)1 69 14 88 34

•

## SWEDEN

Daxten AB  
Södermälärstrand 29, 6tr  
118 25 Stockholm  
Sweden

[info.se@daxten.com](mailto:info.se@daxten.com)

Tel.: +46 (8) 692 65 73  
Fax.: +46 (702) 636 982

•

## AUSTRIA

Daxten Österreich GmbH.  
Künstlergasse 11/4  
A-1150 Wien  
Austria

[info.at@daxten.com](mailto:info.at@daxten.com)

Tel:+43 (0)1879 7765  
Fax:+43 (0)1879 776530