

AutoView Commander

Installer/User Guide

Cybox Computer Products International Ltd.
Cybox House
Shannon Free Zone
Shannon, Co. Clare, Ireland
(Tel) 00353 61 471 877 (Fax) 00353 61 471 871
www.cybox.ie

©1999 Cybox Computer Products Corporation. All rights reserved.

IBM, PC, PC/AT and PS/2 are registered trademarks of International Business Machines Corporation. Microsoft and Kensington are registered trademarks of their respective companies. Logitech, Mouseman and Trackman are trademarks of Logitech, Inc. Cybox is a registered trademark of Cybox Computer Products Corporation. AutoView, Commander, AutoBoot, RSP, 4xP, 1xP and all part numbers are trademarks of Cybox Computer Products Corporation. IntelliMouse is a trademark of Microsoft Corporation.

FCC Notification

Warning: Changes or modifications to this unit not expressly approved by the party responsible for compliance may void the user's authority to operate the equipment.

Note: This equipment has been tested and found to comply with the limits for a Class A digital device, pursuant to Part 15 of the FCC Rules. These limits are designed to provide reasonable protection against harmful interference when the equipment is operated in a commercial environment. This equipment generates, uses and can radiate radio frequency energy and, if not installed and used in accordance with the instruction manual, may cause harmful interference to radio communications. Operation of this equipment in a residential area is likely to cause harmful interference in which case the user will be required to correct the interference at his own expense.

Canadian Notification

This digital apparatus does not exceed the Class A limits for radio noise emissions from digital apparatus set out in the Radio Interference Regulations of the Canadian Department of Communications.

Le présent appareil numérique n'émet pas de bruits radioélectriques dépassant les limites applicables aux appareils numériques de la classe A prescrites dans le Règlement sur le brouillage radioélectrique édicté par le Ministère des Communications du Canada.

この装置は、情報処理装置等電波障害自主規制協議会（VCCI）の基準に基づくクラスA情報技術装置です。この装置を家庭環境で使用すると電波妨害を引き起こすことがあります。この場合には使用者が適切な対策を講ずるよう要求されることがあります。

Table of Contents

Chapter 1 - Product Overview

Feature Overview	1
Compatibility	3

Chapter 2 - Installation

Basic Install	5
Advanced Install	8

Chapter 3 - Basic Operations

Overview	9
Keyboard Control	10
Keyboard Switching	11
System Control & Maintenance	12

Chapter 4 - On-Screen Display Operations

Activating OSD	13
The OSD Window	14
The Command Menu	15
Basic Channel Maintenance	16
The ID Window	18
Administrator Functions	20

Chapter 5 - Channel Scanning

Choosing a Scanning Method	23
Setting the Scanning Order	24
Turning Scanning On and Off	24
Setting the Scanning Dwell Time	25
Scanning and Security	26

Chapter 6 - Appendices

A: Specifications	27
B: Pairing	28
C: Troubleshooting	34
D: Problem Report	39



INSTRUCTIONS: The exclamation mark within an equilateral triangle is intended to alert the user to the presence of important operating and maintenance (servicing) instructions in the literature accompanying the appliance.

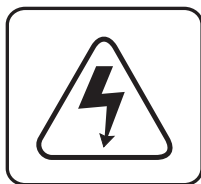

DANGEROUS VOLTAGE: The lightning flash with arrowhead symbol, within an equilateral triangle, is intended to alert the user to the presence of uninsulated “dangerous voltage” within the product's enclosure that may be of sufficient magnitude to constitute a risk of electric shock to persons.

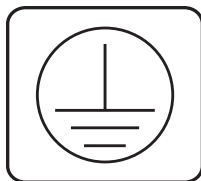

PROTECTIVE EARTHING TERMINAL: A terminal which must be connected to the earth prior to making any other connections to the equipment.

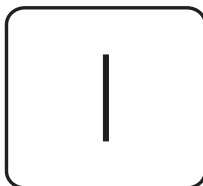

POWER ON: This symbol indicates the principle on/off switch is in the on position.

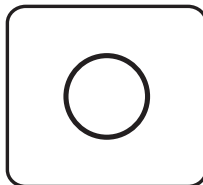

POWER OFF: This symbol indicates the principle on/off switch is in the off position.

1

Product Overview

Feature Overview

The AutoView Commander allows you to control up to 64 PCs with one keyboard, monitor and mouse. Each computer can be up to 30 feet away from the AutoView. The AutoView works with IBM PC/AT and PS/2 systems, and 100% compatible machines with support for VGA, SVGA, XGA and XGA-II video. PS/2 keyboard and PS/2 mouse peripherals are supported through the rear of the unit.

Expansion for up to 64 computers

An AutoView unit will support from one to eight attached PCs, or channels. If more than eight channels are needed, multiple units can be cascaded together for expansion. Up to 2 tiers of units can be connected for a total of 64 attached computers in one system.

AutoBoot technology

The AutoBoot feature boots all attached servers during initial power up or after a power failure. PCs are booted transparently without operator intervention, and may be powered up one at a time or all at once. When the power stabilizes, a channel may be selected. The first available channel is automatically selected upon power-up of the base AutoView.

On-screen display capability

Configure and control your AutoView with on-screen menuing! Name your computer channels anything you wish, then select the desired computer from an easy-to-use menu. Secondary menus let you configure and initiate channel scanning and other system features.

Advanced security for total control over system access

Use the advanced two-level security feature to configure and control server access for every type of user in the system. The administrator has full access privileges; individual users can have viewing or viewing/editing capability for each attached server.

IntelliMouse support

The AutoView offers full support for the Microsoft IntelliMouse.

OSD Configuration Utility The OSD Configuration Utility allows the administrator to easily configure and download a channel list with defined users and access privileges to the entire system. This utility will also read and save your current configuration for extra security.

Push-button & keyboard switching In addition to using the on-screen menus, you can switch computer channels in one of three easy ways: via the AutoView channel push-buttons, with the Scan button or with a simple keyboard sequence.

"Keep Alive" feature AutoView's "Keep Alive" feature allows attached servers to power the unit in the event of an AutoView power failure. This prevents attached PCs from locking up and keeps you from losing time and data.

PS/2 mouse translation For added compatibility with your current equipment, AutoView features PS/2 mouse translation capability. Operated through the AutoView, your PS/2 mouse will work with any attached PC - regardless of whether the computer is serial or PS/2 mouse compatible!

Built-in scanning capabilities A built-in scanning feature allows you to automatically monitor, or scan, your PCs without intervention. When keyboard activity is detected, scanning is suspended until all activity stops. Scanning then resumes with the next channel in sequence.

Status indicator LEDs Indicator LEDs give you constant readings on the status of your AutoView unit. Status, scanning and channel LEDs take the guesswork out of system operation and diagnostics.

A typical AutoView configuration is shown below.

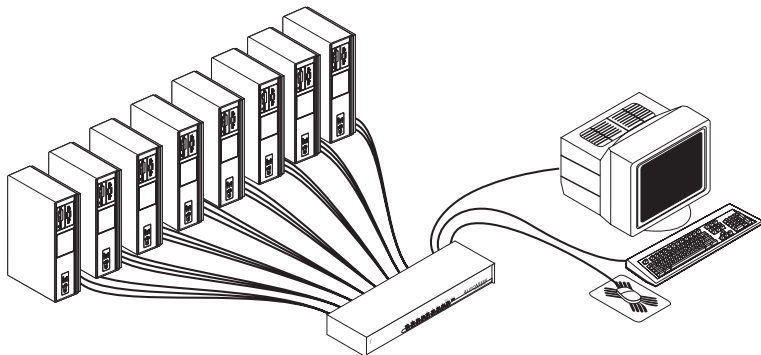

Compatibility

PS/2 peripherals The AutoView requires a PS/2 mouse and keyboard. The following mice are known to be compatible:

IBM PS/2-style	Logitech Trackman
Kensington	Microsoft Serial-PS/2 mouse
Logitech Mouseman (PS/2)	Microsoft IntelliMouse

Other manufacturers' mice may operate with the AutoView. If you experience problems using an untested mouse, contact Cybex Technical Support with the manufacturer and model number of the mouse.

XGA/XGA-II support If you wish to use XGA or XGA-II video, you will need to purchase an adaptor available through Cybex.



2

Installation

Basic Install

1. **Power down all computers that will be part of your AutoView system.**

Connecting your Peripherals

2. Locate your PS/2 keyboard, VGA video monitor and PS/2 mouse.
3. Plug your VGA monitor cable into the port labeled  on the back of your AutoView. Plug your PS/2 keyboard cable and your PS/2 mouse cable into the ports labelled  and  respectively.

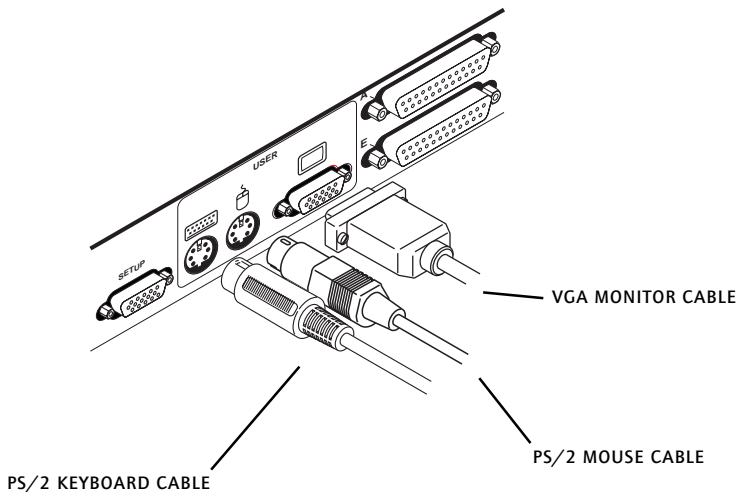

Connecting Computers to the AutoView

4. Locate your first input cable. It will have a 25-pin “D” connector at one end. Plug this cable into any lettered channel port on the rear of the AutoView. The other end of the input cable will have five connectors: a 15-pin “HDD” connector for your video, a 5-pin DIN/6-pin miniDIN connector for an AT or PS/2 keyboard connection, and a 9-pin serial/6-pin miniDIN connector for a serial or PS/2 mouse connection. The PS/2 mouse connector is designated by a yellow band or mouse icon.

Use only the keyboard and mouse connectors which are appropriate for your PC, and leave the others unconnected.

Plug these connectors into the matching ports on your computer.

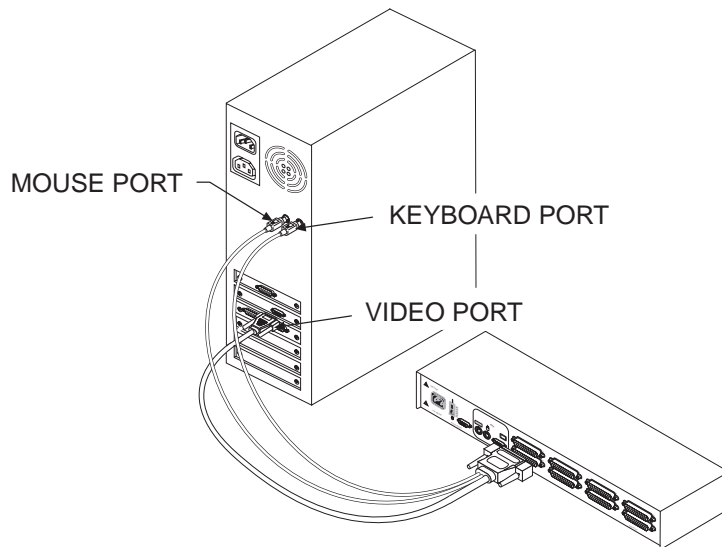

5. Locate your next input cable. Repeat step 4 until all computers are properly attached to the AutoView.

6. Locate the power cord that came with your AutoView unit. Plug it into the IEC power connector on the AutoView. Make sure that the power switch is off, then plug the other end of the power cord into an appropriate AC wall socket. This socket must be near the equipment and easily accessible to allow for unplugging prior to any servicing of the unit.

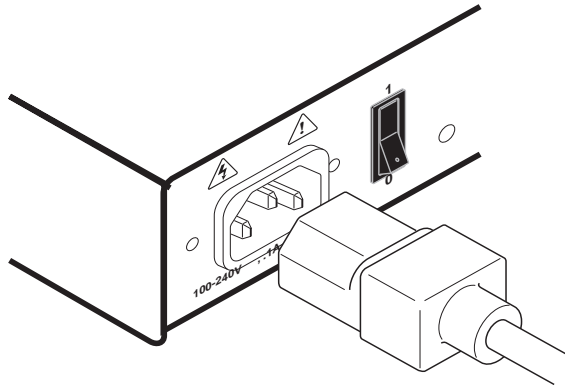



7. Power up your AutoView unit first, then all attached computers.



The AutoView and all attached computers should be powered-down before servicing the unit. Always disconnect the power cord from the wall socket.

Advanced Install

Attaching Multiple AutoView Units

1. Follow steps 1-6 of the Basic Install section.
2. Plug the 25-pin “D” connector of your input cable into any available channel port on the rear of your base AutoView unit.
3. Plug the 15-pin video connector on the other end of the cable into the port labelled  on your first cascading AutoView unit. Plug the PS/2 mouse connector, designated by a yellow band or mouse icon, into the  port. Plug the remaining 6-pin miniDIN keyboard connector into the  port. The 9-pin serial and 5-pin DIN connectors are not used for cascading.

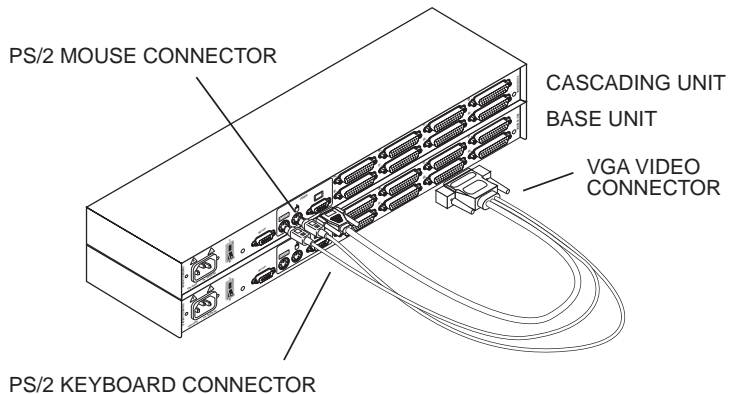

4. Repeat steps 2-3 for every cascaded AutoView unit in your system.
5. Power up your AutoView unit(s) first, then all attached computers.

3

Basic Operations

Overview

Your AutoView may be operated in a non-secure (no password required) or secure (password required) mode. All units ship defaulted to the non-secure mode. For information on implementing password security see the “Administrator Functions” section of chapter 4.

PCs may be powered up one at a time or all at once. No operator intervention is required during booting. As the system stabilizes, the green LEDs over each channel will illuminate, indicating that the attached computer is powered on. The amber LED will illuminate at the active computer. A PC may now be selected via the on-screen display menu or, if you are in non-secure mode, channel push-buttons, the Scan button or keyboard hot-key sequence.

The Scan push-button has two LEDs over it. Press the button momentarily to switch to the next computer in sequence. The amber LED will illuminate briefly during the channel switch. Press and hold the button for 1 second to initiate channel scanning. The green LED will illuminate while you are in scan mode.

There are two status LEDs. The red LED illuminates if an internal failure occurs. The green LED will blink for several seconds during power up while the system performs a self-diagnostic. After initialization, the green LED remains illuminated during normal operation and blinks only when you are in Command Mode.

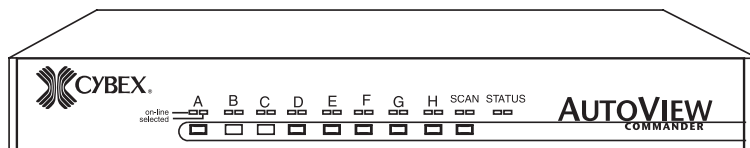

Keyboard Control

The following notational conventions appear throughout this chapter to illustrate commands for operating the AutoView. Whenever you see one of the symbols listed on the left side of the table, substitute the corresponding steps or values listed on the right side of the table.

Convention	Key Sequence or Value
<CM>	Enter Command Mode: 1. Press and hold down the 'Num Lock' key. 2. Press and release the minus (-) key on the numeric keypad. 3. Release the 'Num Lock' key. Note: For alternate hot-key sequences, see 'System Control & Maintenance' later in this chapter.
<Enter>	Press the 'Enter' or 'Return' key. The <Enter> command is used to execute an instruction and exit from Command Mode.
<i>Addr</i>	The letters over the push-buttons on your AutoView are your PCs' addresses. Enter the letter, A-H, for the PC you're selecting. For cascaded systems, enter the address of the base unit first. <i>Example:</i> You have an AutoView unit cascaded from channel B of your base unit. To access the PC at channel C of this second (cascaded) unit, enter BC .
<ESC>	Press the 'Escape' key. The <ESC> command is used to exit Command Mode without executing an instruction.

Keyboard Switching

One of the ways to change the active channel in a non-secured AutoView system is by entering a short sequence of keystrokes on the keyboard. This is called keyboard, or hot-key, switching.

Note: Hot-key switching is only available in the default non-secure state. For more information on secure versus non-secure operation, see the ‘Administrator Functions’ section of Chapter 4.

The first set of keystrokes places your system in Command Mode. As long as you are operating in Command Mode, whatever you type will be interpreted as channel switch commands until the Enter or the Escape key is pressed to terminate Command Mode. None of the keystrokes entered will be forwarded to the attached computer until you exit Command Mode.

Next, enter the address (*Addr*) for the channel you wish to select.

Press **Enter** to accept the new channel. The following command line shows the proper format used to switch your active channel via keyboard.

Key Sequence	Action
<CM>Addr<Enter>	Selects an active channel via keyboard.

Below is a sample of a keyboard switching session, with an accompanying explanation for each step.

Key Sequence	Action
1. <CM>E<Enter>	Selects Channel E on the base unit as the active channel.
2. <CM>CF<Enter>	Selects the AutoView attached to channel C on the base unit, then selects channel F on the cascaded unit.
3. <CM>G<Enter>	Selects Channel G on the base unit as the active channel.
4. <CM>BA<ESC>	Exit Command Mode. The instruction is not executed. Channel G is still the active channel.

System Control & Maintenance

The following commands are used for system control and maintenance. Enter the command sequences to perform the actions described in the table below.

Key Sequence	Action
<CM>Kn<Enter>	Sets the keyboard scan set where <i>n</i> is a scan set number 1-3.
<CM>MR<Enter>	If you hot-plug your mouse cable, you may experience a loss of mouse signal. Use this command to restore the signal if you are using a PC with a standard PS/2 mouse driver.
<CM>MW<Enter>	If you hot-plug your mouse cable, you may experience a loss of mouse signal. Use this command to restore the signal if you are using a PC with a Microsoft IntelliMouse driver.
<CM>AV<Enter>	Displays the current firmware version of the processors inside your AutoView unit. You must be either at a DOS prompt or in a text editor/word processor to view this information.
<CM>H1<Enter>	Changes the hot-key sequence to the default: <ol style="list-style-type: none"> 1. Press and hold down the 'Num Lock' key. 2. Press and release the minus (-) key on the numeric keypad. 3. Release the 'Num Lock' key.
<CM>H2<Enter>	Changes the hot-key sequence to the 1st alternate: <ol style="list-style-type: none"> 1. Press and hold down the 'Num Lock' key. 2. Press and release the asterisk (*) key on the numeric keypad. 3. Release the 'Num Lock' key.
<CM>H3<Enter>	Changes the hot-key sequence to the 2nd alternate: <ol style="list-style-type: none"> 1. Press and hold down the 'Control' key. 2. Press and release the tilde (~) key. 3. Release the 'Control' key.
<CM>ZM<Enter>	Use this command to resynchronize the mouse after a device or computer hot-plug. Repeat, if necessary, until synchronization is re-established. Note: Using this command while the mouse is operating correctly will cause the mouse to lose sync.

4 On-Screen Display Operations

Activating OSD

Activate on-screen display (OSD) by pressing either of the keyboard **Control** keys twice within one second. In nonsecure mode, this brings up the main OSD Window, “Administrator Channel List”.

In secure mode, activating OSD will bring up the “User Login” window. Type in your user name and press **Enter**. The system administrator should login as “Admin”, “Root” or “Administrator”. If the user name is valid, the password window will appear. Type your password and press **Enter**. This will bring up your “Channel List”. If there is no keyboard activity, the login window will timeout after 5 minutes and go to a Cybex screen saver. Press any key to restore the login prompt.

Note: All AutoView units ship in the default non-secure state. For more information on secure versus non-secure operation, see the section ‘Administrator Functions’.

The OSD Window

This window lists all named channels in your AutoView system. They will be listed alphabetically with their channel addresses and access status beside them. When in secure mode, only the channels that are accessible to the logged in user will be listed. (See the section ‘Administrator Functions’ for more information.)

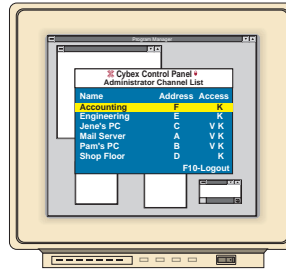

THE MAIN OSD WINDOW

Use your up and down arrow keys, the page up and down keys, or your mouse to select a channel. Move immediately to the top or bottom of the list with the home and end keys. Press a letter while in the main OSD Window, and the Highlight Bar moves to the first channel name beginning with that letter. Press the letter repeatedly to scroll through all channels that begin with that letter from top to bottom. Press **Enter** to make the switch. To exit the OSD Window without changing channels, press **Esc**. To manually logoff when in secure mode, press **F10**.

The Command Menu

Once you have activated the main OSD Window, you can open the Command Menu by either pressing the **Control** key twice or by typing **ALT-M**.

The Command Menu options are selected in the same manner as channels in the OSD Window. Scroll the Highlight Bar up and down and press **Enter** when your selection is highlighted.

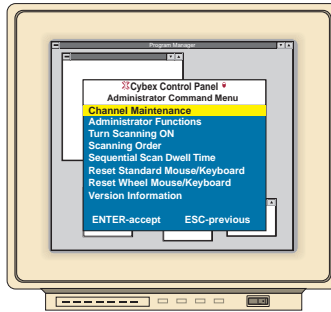

THE COMMAND MENU

If you are operating in non-secure mode or are the system administrator, you will have several options that do not appear in the User level Command Menu: Channel Maintenance, Administrator Functions and Sequential Scan Dwell Time. Channel Maintenance and Administrator Functions are both covered in separate sections in this chapter. Scanning is covered in Chapter 5.

If you experience a loss of mouse signal while using the AutoView, select the 'Reset Standard Mouse/Keyboard' option from this menu for a PC with a standard mouse driver or 'Reset Wheel Mouse/Keyboard' if you are using a PC with a Microsoft IntelliMouse driver. This will reset and in most cases restore your mouse signal. These commands are equivalent to the **<CM>MR<Enter>** and **<CM>MW<Enter>** keyboard command listed in the 'System Control & Maintenance' section of this manual.

Choose the option 'Version Information' to display on your monitor the current version level of your OSD firmware. Press the **Esc** key to clear this information from your screen.

Basic Channel Maintenance

The Channel Maintenance Menu is accessed from the Administrator Command Menu, and is available if you are operating in non-secure mode or if you are the system administrator. Here you can add, delete or alter individual channels.

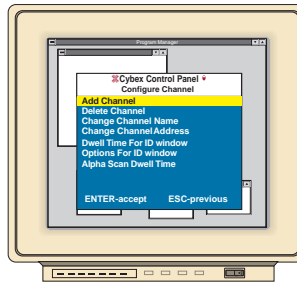

THE CHANNEL MAINTENANCE WINDOW

Adding New Channels (base unit only)

1. Select 'Add channel' from the Channel Maintenance Menu. Type in a new channel name, up to 14 characters long, and press **Enter**.
2. Type in the channel letter for the PC you are naming and press **Enter**.
3. When prompted for another cascade level, type **N** and press **Enter**.

Press **Esc** at any point to exit this operation without adding the channel.

Adding New Channels (with a cascaded unit)

1. Select 'Add channel' from the Channel Maintenance Menu. Type in a new channel name, up to 14 characters long, and press **Enter**.
2. Type in the AutoView channel letter that corresponds to the port that the second cascaded AutoView unit is attached to and press **Enter**.

3. When prompted for another cascade level, type **Y** and press **Enter**.
4. Enter the letter that corresponds to the computer port on the cascaded AutoView you are adding and press **Enter**.
5. When you have finished adding levels (up to two total), type **N** when prompted for another cascade level and press **Enter**.

Press **Esc** at any point to exit this operation without adding the channel.

Deleting an Existing Channel

1. Highlight the channel you wish to delete in the main OSD Window.
2. Press the **Control** key twice or type **Alt-M** to access the Command Menu.
3. Select 'Channel maintenance' from the Command Menu.
4. Choose the 'Delete channel' option.
5. Type **Y** or **N** at the prompt to confirm the deletion and press **Enter**.

Changing Channel Names and Addresses

1. Highlight the channel you wish to change in the main OSD Window.
2. Press the **Control** key twice or type **Alt-M** to access the Command Menu.
3. Select 'Channel maintenance' from the Command Menu.
4. Choose the appropriate option.
5. Enter the new channel name or address and press **Enter** to accept.

Press **Esc** at any point to exit this operation without saving the changes.

The ID Window

The ID Window appears when you change channels and displays the name of the selected channel. This window can be individually configured for each channel in your system. The characteristics of the ID Window can be changed from the Channel Maintenance Menu. This option is only available if you are operating in non-secure mode or if you are the system administrator.

Changing the Size, Colour and Position of the ID Window

1. From the main OSD Window, press the **Control** key twice or type **Alt-M** to access the Command Menu.
2. Select 'Channel maintenance' from the Command Menu.
3. Choose the option 'Options for ID window'.

Follow the procedures outlined in the table below to change the size, colour or position of your ID Window.

Operation	Procedure
Move the ID Window	Use the arrow keys or mouse to move the ID Window's position on the monitor. If the window flickers but does not move, continue tapping the arrow keys until it moves back into range.
Change window background color	Press the <PAGE UP> key to cycle through the available window background colours.
Change text colour	Press the <PAGE DOWN> key to cycle through the available text colours.
Change window size	Use the (+) and (-) keys to change the length of the ID Window.

4. Press **Enter** to accept the changes or press **Esc** to exit the menu without saving the changes.

Setting the ID Window Dwell Time

This menu selection lets you set the time that the ID Window remains on screen after a channel switch. Each channel can be configured independently. The default time is set for 5 seconds.

1. From the main OSD Window, press the **Control** key twice or type **Alt-M** to access the Command Menu.
2. Select 'Channel maintenance' from the Command Menu.
3. Choose the option 'Dwell time for ID window'.
4. Enter a number between 0-255 seconds. Entering **0** disables the ID Window. Entering **255** allows the ID Window to stay on screen the entire time the channel is active.

Administrator Functions

The Administrator Functions Menu is accessed from the Command Menu. Here, you can create an administrator password, set a system logoff time and create individual user logins with specific access and privileges. **This menu is only used if you are running your system in secure mode.** If you configure an administrator password from this menu, your system will then be in secure mode. A lock symbol will appear to the right of the menu headings to indicate secure operation. If you wish to keep your system in the default non-secure mode, return to the Command Menu. For the differences between secure and non-secure modes, see below.

Differences between Secure and Non-Secure Operating Modes

Administrator Password

Entering an administrator password places your system in secure mode. Non-secure systems do not use passwords. To return your system to the default of non-secure mode, simply delete the administrator password. When the administrator password is enabled, user passwords must also be entered or the switch will not be completely secure. The default for users is no password. Simply hit the enter key at the prompt.

Logoff Capability

You have the option of automatically logging off of the system after an administrator defined period of inactivity. Timeout values can be set from 0 to 60 minutes. A value of 0 keeps the user logged in continuously. When the timeout is reached, the current channel is deselected and the display goes to screen saver mode. Users must login again to access system computers. This option is only available in secure mode.

Multiple User Logins

You can create up to four user logins in addition to the system administrator. Use these logins to configure and control server access for every type of system user. The administrator has full access privileges; additional users can have viewing or viewing with keyboard and mouse control capability for each attached server. This option is only available in secure mode.

Push-Button and Hot-Key Channel Selection

While in secure mode, all front panel push-buttons and hot-key channel selection methods are disabled. (This also includes use of the Cybex Remote Switch Panel (RSP)) All other hot-key commands remain operational to the administrator only. In non-secure mode, all push-buttons and hot-key commands function normally.

Creating the Administrator Password

1. Press the **Control** key twice or type **Alt-M** to access the Command Menu.
2. Select 'Administrator Functions' from the Command Menu.
3. Select 'Administrator Password' from the Administrator Menu.
4. Type your password and press **Enter**. (The password is not case sensitive.)
5. Repeat entry of the password for confirmation.

CAUTION: Security is enabled once the password has been created. Store a copy of your password in a safe place.

You should now see the option 'F10 - Logout' at the bottom of your main OSD Window and a lock symbol to the right of the menu headings.

Setting the Administrator Logout Time

1. Press the **Control** key twice or type **Alt-M** to access the Command Menu.
2. Select 'Administrator Functions' from the Command Menu.
3. Select 'Administrator Logout Time' from the Administrator Menu.
4. Enter the number of minutes you wish to pass without keyboard/ mouse activity before the administrator is automatically logged out of the system. The default of 0 keeps the administrator logged on continuously; 60 is the maximum setting.

Setting Up Additional Users

1. Press the **Control** key twice or type **Alt-M** to access the Command Menu.
2. Select 'Administrator Functions' from the Command Menu.
3. Select 'Setup User 1' from the Administrator Menu.
4. Choose the 'Name' sub-menu and enter the name for this user.
5. Choose the 'Password' sub-menu and enter the password and confirm it for this user. (Passwords are not case sensitive.)
6. Choose the 'Access' sub-menu. Here, you will see a listing of all attached servers in the channel list. For each server, choose a level of access for this user by selecting one of the function keys listed on the screen: F5 for no access, F6 for video only or F7 for video and keyboard/mouse capability. The default is set for full access. All changes go into effect as soon as they are made. Press **Enter** when you have completed your configuration.
7. Choose the 'Logout Time' sub-menu. Enter a value in minutes for this user's logout time. A value of 0 keeps the user logged on continuously; 60 is the maximum setting. The default is set for 5 minutes.
8. Press **Enter** to accept your selections and repeat steps 3-8 for each remaining user.

5

Channel Scanning

Choosing a Scanning Method

AutoView's scanning feature allows you to automatically monitor, or scan, your computer channels without intervention. When keyboard activity is detected, scanning is suspended until all keyboard activity stops. Scanning then resumes with the next channel in sequence. Mouse activity will not affect scanning in any way. The length of time each channel remains on the screen, or dwell time, is configurable and can be changed at any time.

There are two ways to scan through the channels in your AutoView system, either sequentially or alphanumerically.

Scanning sequentially allows you to view each of your active channels in the order that they are attached to the AutoView. The amount of time each channel remains on the screen, or dwell time, is configurable and is the same for all channels.

Scanning alphanumerically allows you to scan all your channels in alphanumeric order according to the channel list in the main OSD Window. With this scan method, you can adjust the dwell time for each channel or omit a channel from the scan sequence completely.

Choose whichever method is most appropriate for your configuration.

Setting the Scanning Order

1. From the main OSD Window, press the **Control** key twice or type **Alt-M** to access the Command Menu.
2. Choose 'Scanning order' from the menu.
3. Select either 'Sequential order' or 'Alphanumeric order'.
4. Press **Enter**.

Turning Scanning On and Off

From the OSD menu.

1. From the main OSD Window, press the **Control** key twice or type **Alt-M** to access the Command Menu.
2. Select 'Turn scanning ON' or 'Turn scanning OFF' from the menu. This is a toggle option - only one scanning option will show on the menu at any one time.
3. Press **Enter**.

With the Scan Button (non-secure mode only)

1. You may initiate scanning by pressing and holding the Step/Scan push-button until the SCAN LED illuminates.
2. Scanning may be halted if a channel is selected or if the Step/Scan push-button is pressed again.

By keyboard hot-key sequence (System Administrator or non-secure mode only)

The following key sequences control scanning.

Key Sequence	Action
<CM>SG<Enter>	Enables the scan Go command.
<CM>SH<Enter>	Enables the scan Halt command.

Setting the Scanning Dwell Time

(System Administrators and non-secure mode users.)

For Sequential Scanning

1. From the main OSD Window, press the **Control** key twice or type **Alt-M** to access the Command menu.
2. Choose the option 'Sequential Scan Dwell Time.'
3. Enter a number between 2-60 seconds. The value you enter will be the dwell time for each active channel in the system.

For Alphanumeric Scanning

1. Highlight the channel that you wish to configure in the main OSD Window.
2. Next, press the **Control** key twice or type **Alt-M** to access the Command Menu.
3. Select 'Channel Maintenance' from the Command Menu.
4. Choose the option 'Alpha Scan Dwell Time'.
5. Enter a number between 0-255 seconds. Enter **0** to skip a channel during scanning.

Scanning and Security

In non-secure mode, you may scan channels either alphanumerically according to the channel list or sequentially through all attached servers. Note that with sequential scanning, you will pause at every active channel, regardless of whether that channel has been added to the channel list or not.

In secure mode, you will only scan through channels that appear on the channel list, regardless of the scanning method chosen.

6

Appendices



A: Specifications

Mechanical	Height: 1.7" (4.5 cm) Width: 17.2" (43.7 cm) Depth: 6.5" (16.51 cm) Weight: 4.2 lbs (1.91 kg)
Environmental/ Power	Operating Temperature: 41° (5°C) to 104° (40°C) Storage Temperature: -4° (-20°C) to 122° (50°C) Input Power: 8.0 W Operating Voltage: 100 - 240 VAC Power Frequency: 50 - 60 Hz
Supported Hardware	Computer: IBM PC/AT, PS/2 and 100% compatibles Video Modes: VGA, SVGA, (XGA, XGA-II with adaptor) Maximum Resolution: 1280 x 1024 @ 60 Hz Peripherals: PS/2 keyboard, PS/2 mouse, IntelliMouse (PS/2 only)
Agency Approvals	UL 1950, CSA C22.2 No. 950, EN60950 FCC part 15A, EN55022, EN50082

B: Pairing

Pairing connects two AutoView units serially, allowing access to 16 computers with one keyboard, monitor and mouse without using a computer port. It is used in place of cascading two units. To pair your AutoView units, use the instructions below instead of those given in the Installation chapter.

Initial Configurations

1. Select one of your two AutoView units to be used as the slave unit.
2. Connect your VGA monitor cable to the port labeled  on the back of this unit. Next, connect your keyboard to the port labelled  on the same unit.

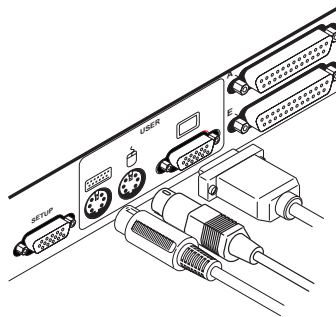

3. Locate the power cord that came with your AutoView unit. Plug it into the IEC power connector on the AutoView. Make sure that the AutoView power switch is off, then plug the other end of the power cord into an appropriate AC wall socket. This socket must be near the equipment and easily accessible to allow for unplugging prior to any servicing of the unit.

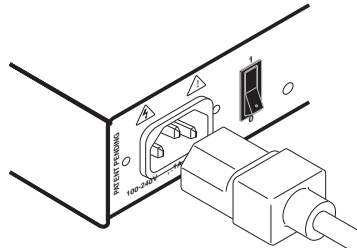

4. Turn the AutoView unit on and press the **Control** key twice to activate the On-Screen Display system. The Administrator Channel list will appear in a pop-up menu.
5. Press the **Control** key twice more to activate the Administrator Command Menu.

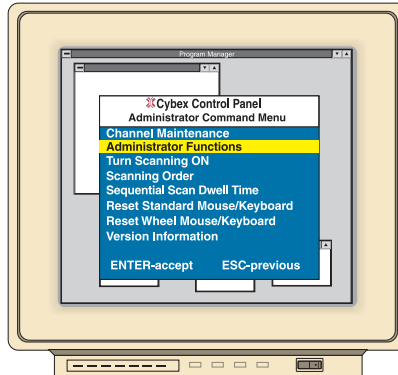

6. Using the arrow keys, highlight 'Administrator Functions' and press **Enter**. This will bring up the Administrator Menu.
7. From here, highlight and select 'Unit Configuration'.
8. Change the unit configuration selection to option 3, 'Paired (Slave)'.

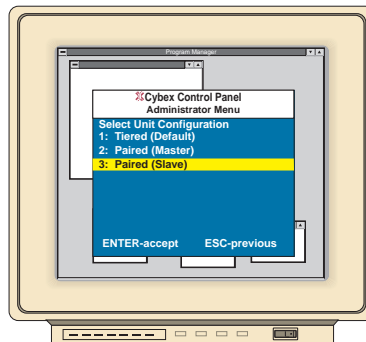

9. Press **Enter** to save your selection. Next, press the **Esc** key repeatedly to exit from the OSD menu.

10. Power down the slave AutoView unit and disconnect the keyboard and monitor.
11. Repeat Steps 2-7 with the remaining master AutoView unit.
12. Now, choose option 2, 'Paired(Master)' for this unit. Press **Enter** to save the selection and then press **Esc** repeatedly to exit the OSD menu.
13. Power down the master unit and disconnect the monitor.

Pairing Connections

1. Locate the pairing cable kit. (CDUAL) It will contain a Y-video cable with two 15-pin male VGA connectors and one 15-pin female VGA connector. It also contains a 9 pin male serial cable.
2. Plug a male VGA connector into the port labelled "VIDEO" on each of the AutoView units.

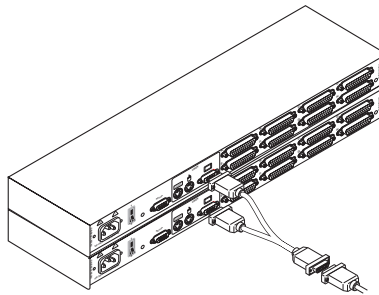

3. Connect the female VGA cable to the end of your monitor cable.
4. Next, connect the serial cable between the ports labelled "SETUP" on the AutoView units.

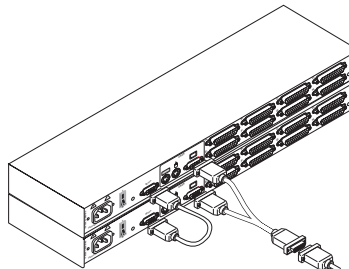

5. Connect a PS/2 mouse to the master AutoView unit.

Connecting Computers to the AutoView

1. Power down the computers that will be part of your AutoView system. Make sure that both of your AutoView units are turned off.
2. Locate your first input cable. It will have a 25-pin “D” connector at one end. Plug this cable into any lettered channel port on the rear of the master AutoView. The other end of the input cable will have five connectors: a 15-pin “HDD” connector for your video, a 5-pin DIN/6-pin miniDIN connector for an AT or PS/2 keyboard connection, and a 9-pin serial/6-pin miniDIN connector for a serial or PS/2 mouse connection. The PS/2 mouse connector is designated by a yellow band or mouse icon.

Use only the keyboard and mouse connectors that are appropriate for your PC, and leave the others unconnected.

Plug these connectors into the appropriate ports on your computer.

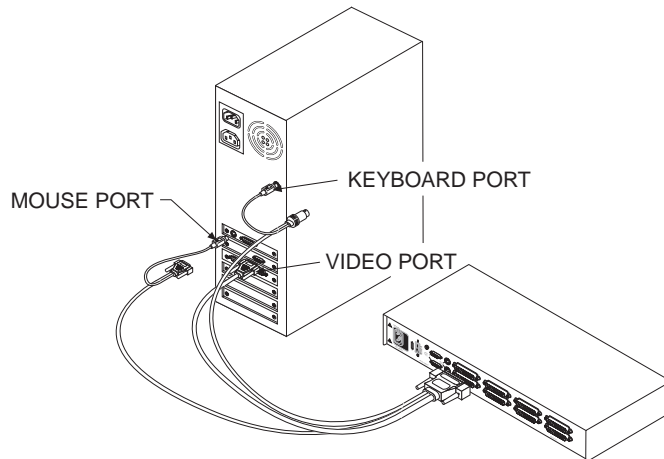

3. Locate your next input cable. Repeat step 2 with all the computers that will be attached to your master AutoView. Next, attach the remaining computers to the slave AutoView.

4. Locate the power cords that came with your AutoView units. Plug each one into the IEC power connectors on the AutoView units. Make sure that the power switches are off, then plug the other end of the power cords into appropriate AC wall sockets. This socket must be near the equipment and easily accessible to allow for unplugging prior to any servicing of the unit.

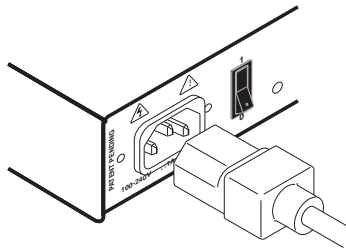

5. Power-up your slave AutoView first followed by your master AutoView, then all attached computers.

The AutoView and all attached computers should be powered down before servicing the unit. Always disconnect the power cord from the wall outlet.

Adding New Channels with Paired Units

1. Select 'Add Channel' from the Channel Maintenance Menu. Type in a new channel name, up to 14 characters long, and press **Enter**.
2. At the next prompt, type in the letter "A" if the PC is attached to the master unit or "B" if it is attached to the slave unit. Press **Enter**.
3. When prompted for another cascade level, type **Y** and press **Enter**.
4. Type the letter that corresponds to the computer port that the computer is attached to on the AutoView and press **Enter**.
5. Type **N** when prompted for another cascade level and press **Enter**.

Press **Esc** at any point to exit this operation without adding a channel.

Note: Keyboard switching is not available on paired units. All other keyboard controls function as described earlier in the manual.

Uninstalling Pairing

1. Press either **Control** key twice to bring up the On-Screen Display Administrator Channel List menu.
2. Press **Control** twice again, select 'Administrator Functions' and press **Enter**.
3. Select 'Unit Configuration' and press **Enter**.
4. Change the unit configuration to 'Option 1, Tiered'.
5. Press **Enter** to save your selection and **Esc** to exit OSD.
6. Disconnect the serial and video cables from both AutoView units.
7. Attach a keyboard and monitor directly to the slave unit.
8. Repeat instructions 1-5 on the slave unit.
9. The units may now be cascaded together or used separately.

Note: Please note that the channel list will need to be modified according to the Basic Channel Maintenance instructions in the manual after uninstalling pairing.

C: Troubleshooting

Our Technical Support staff is ready to assist you with any installation or hardware problems you encounter with your Cybex product. If a problem should develop, follow the steps below for the fastest possible service:

1. Check the troubleshooting tables below to see if the problem can be resolved by following the procedures outlined.
2. If you are unable to find a resolution, recreate the problem when possible. Fill out the Problem Report in Appendix D completely.
3. Call Cybex Technical Support for assistance. Have your Problem Report with you when you call or fax it to Technical Support directly. To expedite assistance, have this manual with you when you call, along with a copy of your invoice giving the date purchased and other identifying data.

Symptom	Action
No status light	Verify unit is turned on. Check power cable. If status light still does not illuminate, turn off the unit and check the fuse located under the power cord connector. If the problem persists, contact Cybex Technical Support.
Red status LED illuminated	Internal unit failure. Contact Cybex Technical Support.
Both amber and green Scan LEDs illuminated	If Scan button is depressed for longer than 3 seconds, both LEDs will illuminate momentarily and a reset is sent to the unit. In order to initiate scanning, depress the Scan button for 1-2 seconds only. If both LEDs remain illuminated, call Cybex Technical Support.
Green channel LED not illuminated	Verify that the computer is powered on. Check the cabling between your computer and the AutoView. Verify that a keyboard works when plugged directly into your PC. If the problem persists, contact Cybex Technical Support.

Symptom	Action
Unable to hot-key switch to a channel	<p>Verify that no OSD menuing windows are up on your monitor. You must escape from all OSD menus to enable hot-key switching.</p> <p>Verify that you are not in secure mode. (No lock symbol on OSD screen.)</p> <p>Verify that you are in hot-key mode by checking to see if the green status LED is blinking. If it is not, press escape and try going into command mode again. If the problem persists, contact Cybex Technical Support.</p>
Unable to push-button switch to a channel	<p>Verify that the channel being selected is not serving as an expansion unit.</p> <p>Verify that you are not in secure mode. (No lock symbol on OSD screen.)</p> <p>Verify that a computer is attached to that channel. If the problem persists, contact Cybex Technical Support.</p>
No video	<p>Verify that the video cable between the PC and the AutoView is correctly connected. Verify that the monitor cable is correctly connected to the AutoView.</p> <p>Power down the computer. Connect the monitor directly to the computer and power up again. If the monitor operates correctly direct to the computer, contact Cybex Technical Support. If it does not, try another monitor.</p>
Mouse jumps or "hugs" screen	<p>If the mouse has been hot-plugged while running in Windows, you may need to close and restart Windows.</p> <p>If the mouse still does not function, try the mouse resynchronization command <ZM>. (For instructions on command mode, see "Basic Operations'.) If the problem persists, contact Cybex Technical Support.</p>

Symptom	Action
<p>Mouse is inoperable on one computer channel</p>	<p>If the mouse is inoperable on a channel, try the mouse reset command <MR> or <MW> with that PC selected. (For instructions on command mode, see 'Basic Operations'.)</p> <p>Verify that the cables from the computer to the AutoView are connected properly.</p> <p>Make sure that you have keyboard/mouse privileges for that channel.</p> <p>Verify that the mouse driver and application are configured properly for mouse support.</p> <p>Verify that the computer works properly with a mouse connected directly to it. If the problem persists, contact Cybex Technical Support.</p>
<p>Mouse is inoperable on all computer channel</p>	<p>Verify that the mouse is plugged into the correct PS/2 port on the back of the AutoView.</p> <p>Verify that the mouse is PS/2 style and a supported brand. (See the 'Product Overview' chapter for more information.)</p> <p>Try the mouse reset command <MR> or try the 'Reset standard mouse/keyboard' command from the OSD Command Menu for computers using PS/2 mice. Use <MW> or 'Reset wheel mouse' for computers using the Microsoft IntelliMouse. (For instructions on command mode, see the 'Basic Operations' chapter.)</p> <p>Verify that the mouse works when connected directly to a computer.</p> <p>Cycle power to the AutoView unit. (You do not have to power down your computers for this.) If the mouse remains inoperable, power down all attached computers, cycle power on the AutoView, then repower the computers. If the problem persists, contact Cybex Technical Support.</p>