

CyberView

minimum rack space, maximum control.

RKP115/117/119 SERIES

LCD Keyboard Drawer

And Optional Integrated KVM
(Keyboard, Video & Mouse) Switch



RKP115/117/119

CyberView RKP115 / 117 / 119 Series A 1U rack mountable LCD, keyboard and KVM drawer. Using the optional integrated USB or PS/2 KVM allows you to connect to up to 16 servers, in addition to this the KVM drawer can be cascaded 'or stacked' with our CV series of KVM switches to enable access to up to 128 servers. Remote or Two consoles KVM can either be, via the World Wide Web using secure IP access or within the building using a secure physical KVM extender connection via a Cat5 cable.

PRODUCT FEATURES & BENEFITS

1U LCD Screen/Keyboard Drawer
Space saving 1U design, incorporating LCD screen & keyboard
15" / 17" / 19" TFT LCD Screen
Available in 3 LCD screen sizes, all in a 1U unit
Built in on screen display controlled by integral membrane switches
Allows adjustment of color, contrast, brightness, H Position, V position, Auto Configure, OSD, etc
Unique modular mechanical design
Allows easy component level replacement and provides a KVM migration path
Extended Slide rails provide clearance distance between rack panel mounts and the rear of the LCD Screen
Allows protruding equipment i.e. servers and patch panels to be mounted directly above the drawer, without interference
Slide rails have two friction stops to prevent movement of the keyboard
Allowing comfortable working on unit while maintaining safety practices
A selection of keyboards and mouse options
Available with notebook keyboard and either trackball or touchpad mouse
Full selection of keyboard languages
Available in European (UK), US, Spanish, German, French, Italian & Norwegian

All mounting hardware included
Allows simple, quick and secure installation

WITH KVM SWITCH:-

8 or 16 Port KVM
Available with PS/2 or USB KVM switch options, cascade able up to 128 servers
Built in integral KVM membrane switch
Allows user to choose server selection via membrane button or 'hot' keys via OSD
Multiplatform
Provides instant switching between PC's, SUN's, IBM's, HP's, Compaq, and DELL platforms
Stay Alive Feature
Safeguards server for power loss to switch
Access Password Security
Supports eight character password protection and search feature for specific PC or server name
Auto Scan Mode
Monitor your servers at intervals 5-99 seconds, set by user
Supplied with 8 x 6 C series KVM connecting cables
Supports good rear cable management via the use of 8 x 3 in 1 KVM Cables

THE CYBERVIEW SOLUTION...

CyberView offers its users a flexible, space saving, cost effective method of managing multiple servers from a single unit, either locally within the data centre, or remotely via the World Wide Web using secure IP access.

CyberView is available in 1U and 2U height options, depths include 440mm for 600 deep racks or 650mm for 800 deep racks, with complete unit configuration flexibility of simply LCD drawer, Keyboard drawer, LCD Keyboard Drawer or LCD Keyboard Drawer with KVM (Keyboard, Video and Mouse) switch.

To cater for today's ever demanding working environments and applications CyberView is available in 15, 17 or 19" LCD screens with a wide selection of keyboard layouts and languages, including vendor application specific units i.e. full SUN Microsystems Solaris v10 compatibility when using our S Series solutions.



Austin Hughes
Europe

©Austin Hughes Europe Limited 2005, All Rights Reserved.



LCD SPECIFICATION RKP115/117/119 SERIES

PANEL	15" LCD SERIES	17" LCD SERIES	19" LCD SERIES	20" LCD SERIES
DISPLAY TYPE	Active matrix TFT colour LCD	Active matrix TFT colour LCD	Active matrix TFT colour LCD	-----
MAX RESOLUTION	1024 x 768 XGA	1280 x 1024 SXGA	1280 x 1024 SXGA	-----
PIXEL PITCH	0.297(H) x 0.297(W) mm	0.264(H) x 0.264(W) mm	0.294(H) x 0.294(W) mm	-----
CONTRAST RATIO	300:1	500:1	700:1	-----
BRIGHTNESS	450 cd / m2	300 cd / m2	300 cd / m2	-----
RESPONSE TIME	Tr=5 / Tf=20 ms	Tr=3 / Tf=10 ms	Tr=15 / Tf=10ms	-----
DISPLAY COLOURS	16.2M	16.2M	16.7M	-----
VIEWING ANGLE (TYPICAL)	140 (Horiz.) / 115 (Vert.)	150 (Horiz.) / 135 (Vert.)	150 (Horiz.) / 135 (Vert.)	-----
OPERATING TEMP (°C)	0 to 50	0 to 50	0 to 50	-----
STORAGE TEMP (°C)	-25 to 60	-25 to 60	-25 to 60	-----

KEYBOARDS

Supporting Layouts



'E' TYPE KEYBOARD	'B' TYPE KEYBOARD	'D' TYPE KEYBOARD	'T' TYPE KEYBOARD
Notebook With Touch Pad Mouse	Notebook With Trackball Mouse	Compact With Integrated Trackball	Compact With Integrated Touch-pad Mouse

KVM SPECIFICATION

MODEL NUMBER	-801 / -S801 / -1601 / -S1601	-802 / -S802 / - 1602 / -S1602		-IP802 / -IP1602 / -IPS802 / -IPS1602
		Local Console	CAT.5 Remote Console	-----
PC PORTS	8 / 16	8 / 16	N/A	8 / 16
CONSOLE PORTS	1	1	1	1
PC SELECTION	On Screen Disp. / Hot Keys / Push Button	On Screen Display Menu / Hot Keys / Push Button		On Screen Display Menu
LED	1 Bank LED	1 Bank LED	1 Power LED Green	1 Bank LED
	8/16 Online LED Green	8/16 Online LED Green	1 Status LED Red	8/16 Online LED Green
	8/16 Selected LED Red	8/16 Selected LED Red	-----	8/16 Selected LED Red
OSD CONTROL	Yes	Yes		Yes
SCAN INTERVALS	5 - 99 Seconds	5 - 99 Seconds		5 - 99 Seconds
KEYBOARD & MOUSE EM.	PS/2 or USB	PS/2 or USB		PS/2 or USB
VGA RESOLUTION (MAX.)	1920 x 1440	1920 x 1440	1600 x 1200	Local 1600x1200, Remote 1280x1024
CAT.5 CABLE LENGTH (MAX)	N/A	N/A	1000 feet	-----
BANDWIDTH	200MHz	200MHz	150MHz	200MHz
CASCADE LEVEL	8 levels	8 levels		8 Levels
PC CONNECTIONS (MAX)	120/128	120/128		120/128
LOCAL CONSOLE PORTS	-----	-----	-----	1
REMOTE CONSOLE PORTS	-----	-----	-----	1
REM. CONSOLE CONNECTOR	-----	-----	-----	RJ45 8P8C
SERIAL PORT	-----	-----	-----	1
REMOTE WEB BASED ACCESS	-----	-----	-----	Internet, LAN/WAN, Dial Up Modem
REMOTE BROWSER SUPPORT	-----	-----	-----	Microsoft IE, Netscape Navigator, Mozilla
DATA ENCRYPTED	-----	-----	-----	Secure Socket layer SSL v2 / 23

SIZE SPECIFICATION

UNIT TYPE	15" UNIT	17" UNIT	19" UNIT	20" UNIT
UNIT DIMENSIONS (CM)	43.9 x 4.45 x 60	43.9 x 4.45 x 60	44.2 x 4.45 x 65	-----
PACKAGED DIMENSIONS (CM)	73.5 x 18 x 57.5	73.5 x 18 x 57.5	78.5 x 18 x 57.5	-----
UNIT WEIGHT (KG)	10	12	14	-----
PACKAGED WEIGHT (KG)	18	21	23	-----

POWER SUPPLY

REMOTE ADAPTER	110V-220V AC Input - 12V 5A Output
ADAPTER SIZE	10.8(L) x 6.1 (W) x 3(H) cm
CABLE LENGTH (MAINS TO ADAPTER)	182cm
CABLE LENGTH (ADAPTER TO UNIT)	180cm
SAFETY APPROVAL	UL / CE

OPTIONS AVAILABLE:



NOTE: Technical Information.
All information contained in this information sheet was correct at the time of going to press. Images are used for illustration purposes and are subject to change at the manufacturers discretion. E&OE.

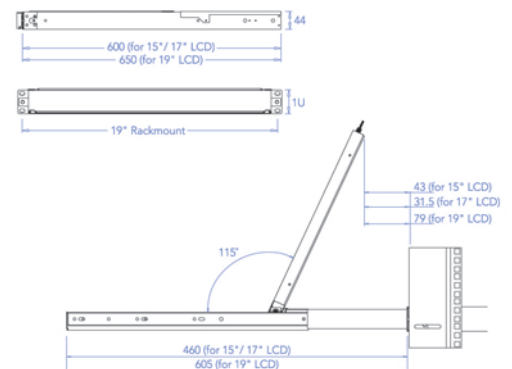

Unit : mm